

WGANZ
Guide to Window
Installation
as described in
E2/AS1
Amendment 10



Ver 1.3 - 1 December 2014

The WANZ Technical Committee have reviewed E2/AS1 Amendment 6 and agree that the erratum does not affect the content of this document.

Ver 1.4 - 1 November 2017

The WANZ Technical Committee have added details pertaining to the installation of full height windows and doors pushed up to the soffit lining.

The WANZ Technical Committee have reviewed E2/AS1 Amendment 7 and agree that the erratum does not affect the content of this document.

Ver 1.5 - 1 August 2019

The Window & Glass Association of NZ Window Committee have reviewed E2/AS1 Amendment 8 and agree that the erratum does not affect the content of this document.

Ver 1.6 - 17 January 2022

Support bar screws noted as pan head.

The Window & Glass Association of NZ have reviewed E2/AS1 Amendment 10 and note that the erratum does not affect the content of this document.

Ver 1.7 - 23 November 2022

Window fixing nails / screws clarified. Sections C3, C3a, D3, D3a

Contents

Overview	Page	5
Objective	Page	5
Scope	Page	5
Opening Preparation	Page	7
Step P1 – Preliminary Check		8
Step P2 – Cut the Underlay		9
Step P3 – Flexible Flashing Tape		10
Cavity Construction	Page	11
Step C1 – Sill Support Bar		12
Step C1a – Sill Support – Full Height		16
Step C2 – Position the Unit		19
Step C2a – Position the Unit – Full Height		21
Step C3 – Fixing		23
Step C3a – Fixing – Full Height		24
Step C4 – Air Seal		25
Step C5 – Head Flashing		26
Supplementary Detail 1.1 – Full Height to Soffit		31
Supplementary Detail 1.2 – Part Height to Soffit		34
Components – Cavity Construction	Page	32
Typical Details	Page	
Masonry Veneer		40
Stucco		42
Bevel Back Weatherboards		43
Rusticated Weatherboards		44
Fibre Cement Weatherboards		45
Horizontal Profiled Metal		46

Fibre Cement Sheet	47
EIFS	48
Direct Fixed Claddings	Page 49
Step D1 – Sill Tray Flashing	50
Step D2 – Position the Unit	54
Step D2a – Position the Unit – Full Height	55
Step D3 – Fixing	57
Step D3a – Fixing – Full Height	58
Step D4 – Air Seal	59
Step D5 – Head Flashing	60
Components – Direct Fix Claddings	Page 65
Typical Details	Page
Bevel Back Weatherboards	68
Rusticated Weatherboards	69
Vertical Shiplap Weatherboards	70
Board & Batten Weatherboards	71
Fibre Cement Weatherboards	72
Vertical Profiled Metal	73
Fibre Cement Sheet	74

Overview

In 2009 the Department of Building & Housing invited WANZ to become a part of a working group set up to assist in a technical review of E2/AS1. This was seen by WANZ as an opportunity to address some of the confusion being experienced within the wider building community through having two generic window installation systems available. The net result, in terms of window installation, was E2/AS1 Amendment 5 which effectively merged previous versions of the Acceptable Solution with WANZ WIS. There are some additional items included in the document, which will be covered off as a part of this guide.

Objective

The objective of this document is an attempt to offer a better understanding of window and door installation as described in E2/AS1 Amendment 10.

The details and drawings used within E2/AS1 to describe window and door installation are two dimensional, cross sectional details which show a required end result. However, often a more in-depth sequential approach might describe the process better to the end user. This is what WANZ have attempted to do with this document by providing a step by step guide to the details offered by this latest version of the Compliance Document E2/AS1.

Scope

Because this document is designed as a Guide to E2/AS1 Amendment 10, its scope is identical to that listed in Section 1 (*Pg. 25*) of the Acceptable Solution.

E2/AS1 Amendment 10 contains the details for a number of generic solutions covering a majority of the typical building situations encountered on building sites in New Zealand. Obviously, there are many more situations that are not covered within its pages. The details for these situations will need to be specifically designed to suit the conditions being encountered. However, the principles expressed within the document, and in these pages, will provide a good foundation for the development of specific details.

For the purpose of this guide it is assumed that the building designer has already worked through the Risk Matrix and selected an appropriate cladding option, either Cavity Construction or Direct Fixed cladding.



Note: *There are a series of size limitations as expressed in Clause 9.1.10.1 Scope (Pg. 103)*

Where your window or door unit exceeds the limitations set out within this clause, please contact your window supplier for alternative details.

9.1.10.1 Scope

This Acceptable Solution is limited to aluminium window and door joinery that:

- a) Has horizontal window and door heads only
- b) Has maximum frame dimensions of 5000 mm wide or 5000 mm high, and a maximum overall frame area, for any one frame, of 13.5 m², or
- c) For sills to floor level, has maximum width of 6 m and maximum overall frame area is 16 m².

Amend 5
Aug 2011

Amend 2
Jul 2005

Opening Preparation

The preparation of the wall opening prior to the installation of the window or door is essentially the same regardless of cladding option. The following offers a ***step by step guide*** to the process.



Step P1 – Preliminary Check

Before proceeding with the installation and preparation of the wall underlay, the installer should examine and confirm that the sill trimmer is essentially level, straight and free of twist. It is particularly important that it is well secured and does not slope toward the interior of the building.

If necessary, the sill trimmer should be planed to ensure it does not exhibit any of the above conditions.

The sill trimmer must be designed to comply with NZS3604.

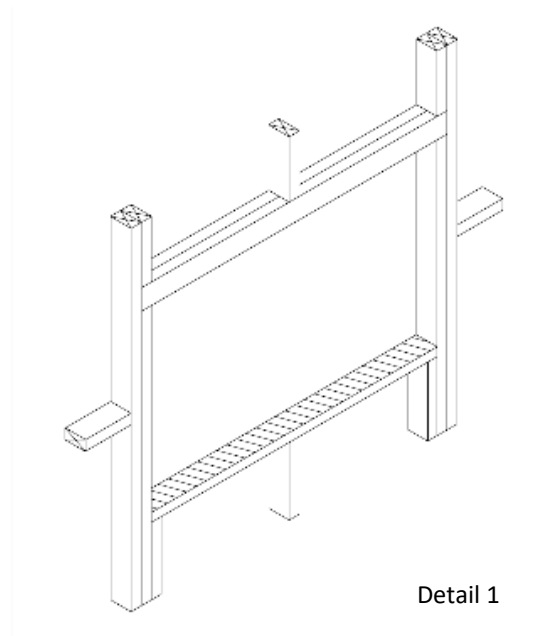

Note: Projects within the new Extra High wind zone require the use of a Rigid Underlay in addition to and underneath a flexible wall underlay, except as noted in the attached comment.

This needs to be considered when sizing the windows.

9.1.7.2 Rigid wall underlays, in association with drained cavities (including direct fixed corrugated profiled metal), are required in Extra High wind zones. Refer to Table 3 and Table 23. Rigid underlays are also required to external walls of attached garages that are unlined. Refer Paragraphs 1.1.1 and 9.1.3.4 c). Rigid wall underlays shall be in accordance with Table 23, and shall:

- a) Be minimum 7 mm H3 plywood, or 6 mm fibre cement sheet
- b) Be installed with sheet edges fixed over solid framing
- c) Be over-fixed with a flexible wall underlay from Table 23 and installed as in Paragraph 9.1.7.1

COMMENT:

Some proprietary systems may not require the addition of a flexible underlay



Step P2 – Cut the Underlay

Clause 9.1.5 a) describes the application of a flexible wall underlay.

Amend 5
Aug 2011

9.1.5 Wall underlays to wall openings

Prior to window or door installation:

- a) Flexible *wall underlay* shall be cut and dressed into all sides of openings as per Figure 72A and B,

Amend 5
Aug 2011

To achieve this, follow these steps;

- a. Cut the building underlay at 45° away from each corner.
- b. Fold the flaps tightly into the opening and secure to the framing on all sides.
- c. Trim off excess underlay after fixing.



Note: Figures 72A & 72B do not show the inner extent of the flexible wall underlay. The industry trend has been to cut this off at the inner corner of the framing as wrapping around sometimes interferes with the internal linings. Ensure the underlay is fixed tightly to the framework.

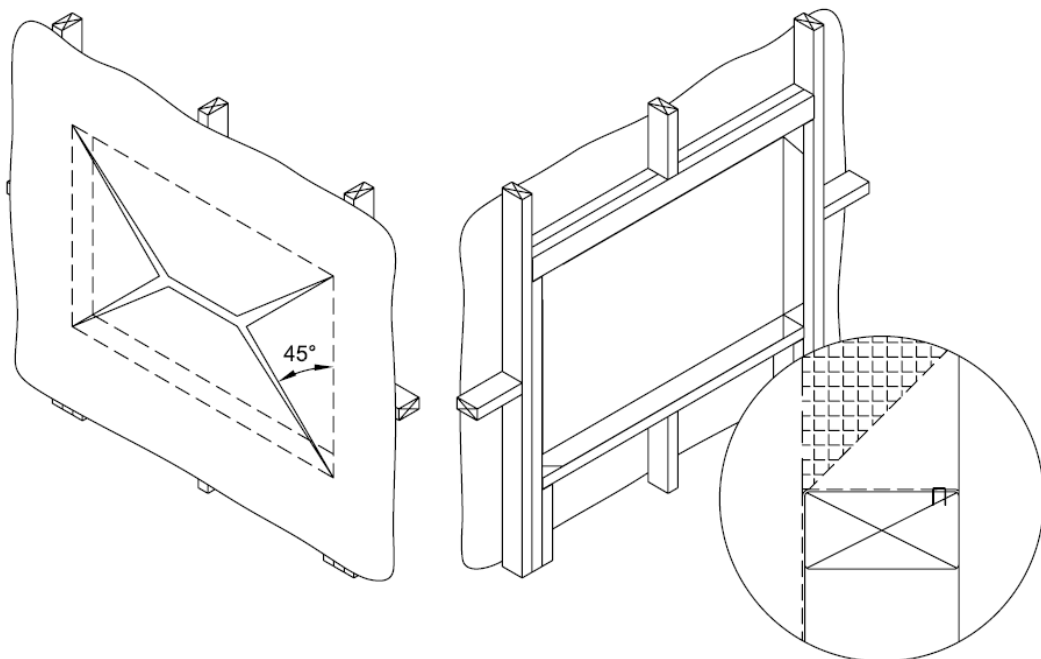

Detail 2



Step P3 – Flexible Flashing Tape

After ensuring the flashing tape to be used meets the criteria set out in *Clause 9.1.5 b)*, follow these steps to satisfy the clause;

Amend 5
Aug 2011

- b) *Flexible flashing tape* shall be applied to head and sill *framing* as shown in Figures 72A and 72B. *Flexible flashing tape* shall:
- i) comply with Parts 3.2 and 4 of ICBO Acceptance Criteria AC148, and
 - ii) be compatible with the *wall underlay*.

Amend 5
Aug 2011

- a. Cut the flashing tape for the sill at least 200mm wider than the opening.

Amend 5
Aug 2011

COMMENT:

Dressing the *wall underlay* around the *framing* timber and providing a flexible *air seal* limits airflows around the window reveal.

The *flexible flashing tape* keeps any water that does get past the *cladding*, or through the joinery, from direct contact with the timber.

- b. Fit the tape, as described in the manufacturers literature, with the inner edge of the tape flush with the inside line of the framing, so that it extends a minimum of **100mm** up each jamb ensuring timber framing is covered.
- c. Ensure the tape is securely adhered to the underlay on all surfaces and fits tightly into each of the corners.
- d. Cut two more pieces of tape at least **200mm** long and fit into each of the upper corners as described above ensuring timber framing is covered.

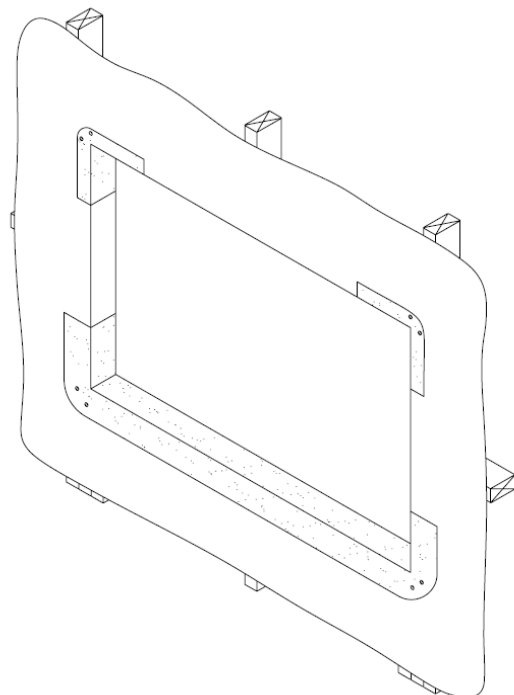

Detail 3



Note: Ensure all exposed timber is covered, particularly in the corners. This may mean the tape has to extend further than nominated.

Cavity Construction

Clause 9.1.10.2 c) & d) describes the basics of window installation for wall claddings over a cavity.

- c) Window openings for *wall claddings* over *drained cavities* shall be as shown in Figure 72B. Note there shall be no sill *flashing*.
- d) For cavity fixed *claddings*, windows and doors shall finish against the *cladding*, except for flat fibre cement and ply *claddings* that require a 5 mm stand-off to allow for sealant weather seals between facings and *cladding* – eg, Figure 116.



Note: *The use of a sill tray with cavity construction should be avoided. Its use will impact on the airflow into the cavity around the window and therefore its ability to pressure equalise. If a sill tray is desired, then a Direct Fix type solution for the window installation must be created.*

- b) *Claddings* over a *drained cavity* shall have:
 - iii) window sills as shown in Paragraphs 9.2 to 9.9, without sill *flashings*



Step C1 – Sill Support Bar

Clause 9.1.10.5 b) v) describes the requirements of the Sill Support bar in terms of compliance with E2/AS1. There are some important points to note;

- a. Support is required on all window and door units with a trim opening over 600mm wide,
- b. The sill support bar must comply with EM6, E2/VM1 & B2/AS1,
- c. Must be installed prior to the window or door unit.
- d. The bar must be fitted in a manner that does not trap water on the sill trimmer

v) Sill support bars and mechanisms for all doors, and for windows with a trim opening wider than 600 mm. Support bars and mechanisms shall comply with BRANZ Evaluation Method EM6, E2/VM1 and B2/AS1. Support bars and mechanisms must be installed prior to installation of the window or door.

The comment following *Clause 9.1.10.5 b) v)* makes reference to ensuring the support bar is appropriate for the application for which it is being used. The EM6 test will allow the calculation of an acceptable weight limit for the support mechanism being used and the size and frequency of the fixings required to achieve the support.

COMMENT

Support bars and mechanisms are rated for their capacity to support the total weight of a joinery unit when installed at given offsets from the frame depending on *cladding* type. Designers select the an appropriate complying support mechanism for the joinery weight. Manufacturers provide build-in instructions for support bars and mechanisms.

Clause 9.1.10.5 c) also makes this note regarding the design of the sill support bars.

Sill support bars and mechanisms must be designed to not impede the possible drainage of water from surfaces of sill *flashing* tape, and permit an air passage (of at least 1000 mm²/m sill width) from the *drained cavity* to the window/door trim cavity.



Note: Selection of the appropriate sill support bar is important. Please refer below for a guide to the options offered by WANZ members.

Figure 72B shows the general arrangement of the sill for a window installed into wall claddings, over a cavity.

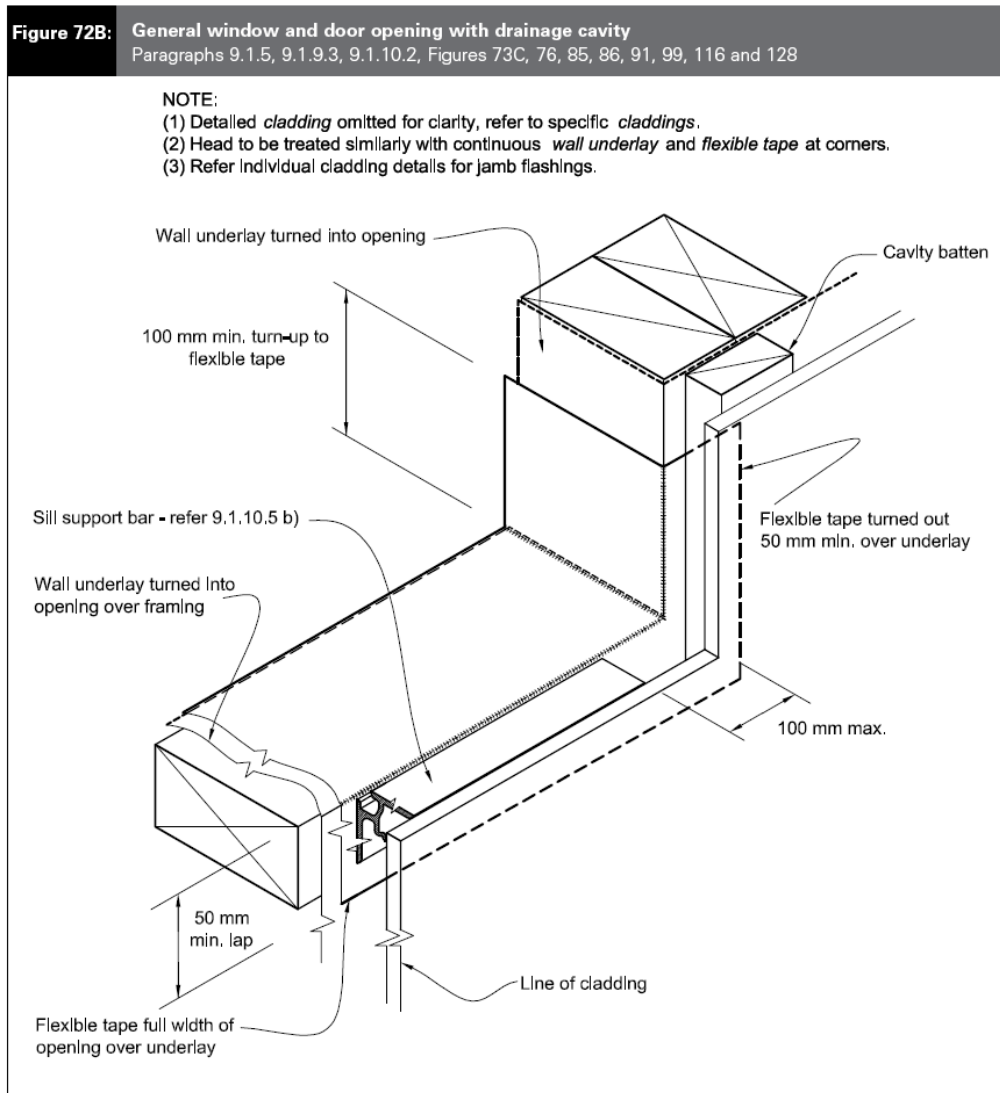

Note: Figure 72B indicates that the sill support bar may be up to 100mm short of the trim opening at either end. It is recommended that the bar is installed to the full width of the opening to ensure it picks up the window or door frame support blocks. However, in some cases the use of non-proprietary corner soakers may require shortening of the bar.

The WANZ sill support bars, as described on the Components page (Page 37) and below, offer not only support to the window or door unit, but also drainage and ventilation of the trim cavity. The WANZ bars have been tested to EM6 and have demonstrated compliance with E2/VM1. In order to comply with these documents, they must be used in a continuous length across the trim opening.

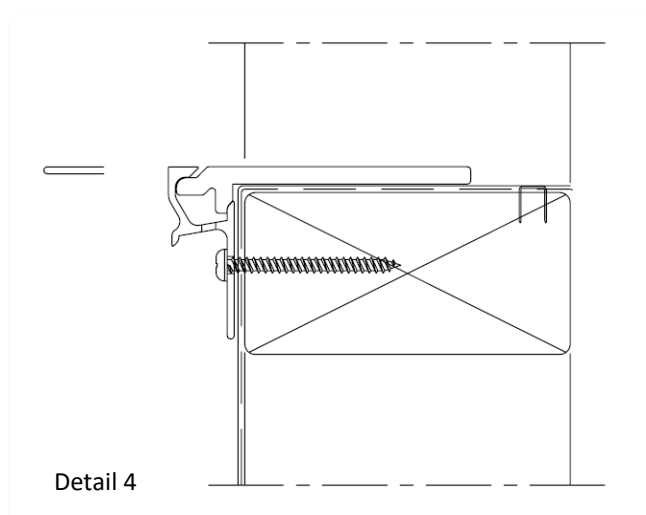

- a. The sill support bar is positioned below the opening, and set so that the upper edge sits a minimum of 5mm above the sill trimmer

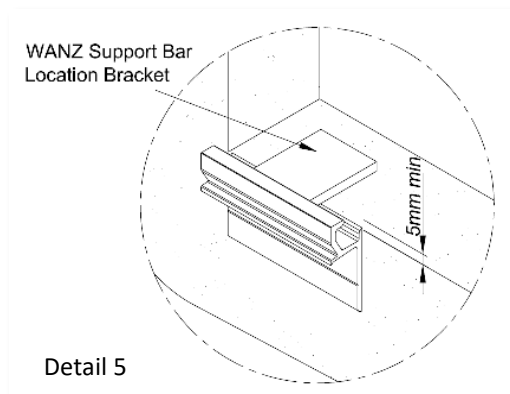

The WANZ sill support bar is supplied with locator blocks which are a quick and easy method of setting the bar in the correct position.

The locator blocks are designed to be re-used but can remain if desired.

- b. After fitting a locator block at each end of the bar, position it into the trim opening. Using a level find the high end of the bar and fix the bar in place. Now adjust the other end of the bar to level and fix this end.

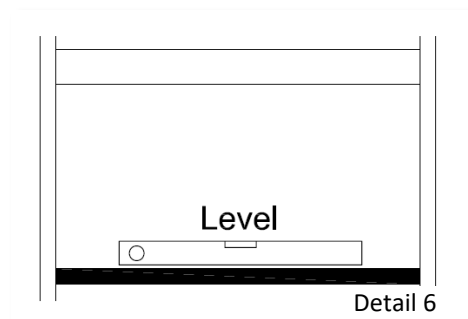



Note: *The WANZ sill support bars, as described on the Components page (Page 37) are designed to fit a number of different claddings and circumstances. Selection of the correct bar, and its installation, is important. Please refer to the following to assist in the selection.*

COMMENT

Support bars and mechanisms are rated for their capacity to support the total weight of a joinery unit when installed at given offsets from the frame depending on *cladding* type. Designers select the an appropriate complying support mechanism for the joinery weight. Manufacturers provide build-in instructions for support bars and mechanisms.

Fixing Options;

- i. The generic fixing method into timber is 10g x 50mm pan head stainless steel screws, positioned at each end of the bar and at a maximum of 300mm centres between.
- ii. When fixing to concrete, the Heavy-Duty bars must be used. The same screws and fixing centres, as noted above, apply but the screws would be driven into nylon plugs or similar.
- iii. For concrete the screws may be substituted for 6mm masonry anchors, at the same centres. However, in order to achieve the required edge clearance that these fasteners require, the Heavy-Duty bar must be re-drilled to suit.



Step C1a – Sill Support – Full Height

For window or door units that extend to the floor there are two sill support bar options available;

- a. Where the sill support bar is installed as described in Step C1 above, using the Heavy-Duty bar.

The major difference here would be where the bar is being fitted to a concrete floor. In this case the fixing sizes and positions would be identical except that the screws would drive into nylon plugs or similar.

If the installer prefers to use masonry anchors, these can be substituted as noted in vii) above. Regardless of fixing type, ensure edge clearances, as recommended by the anchor supplier, are observed.

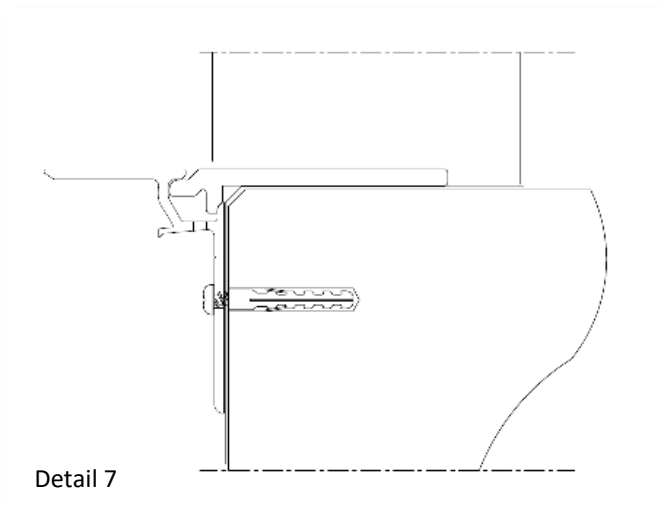

- b. Included in the WANZ Sill Support Bar range is a bar designed for situations where there is insufficient room to fit a standard bar, i.e. units fitted as an option over a masonry veneer rebate or those set over an enclosed deck.

The full height bar is designed to be fixed vertically into the top of the floor / rebate instead of into the face of the floor.

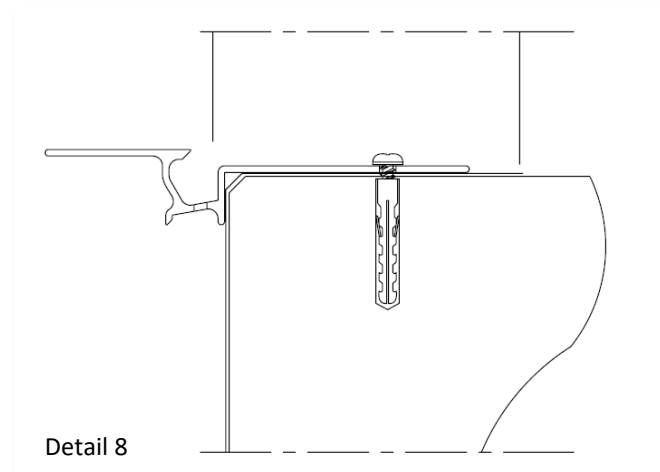

As with the standard bar it must be installed level. This may require packing between the substrate and the bar to ensure weight is adequately supported. For fixing type and centres refer above.



Note: Fixing holes into concrete should be pre-filled with sealant prior to the installation of the fixing as noted in Figure 17A.

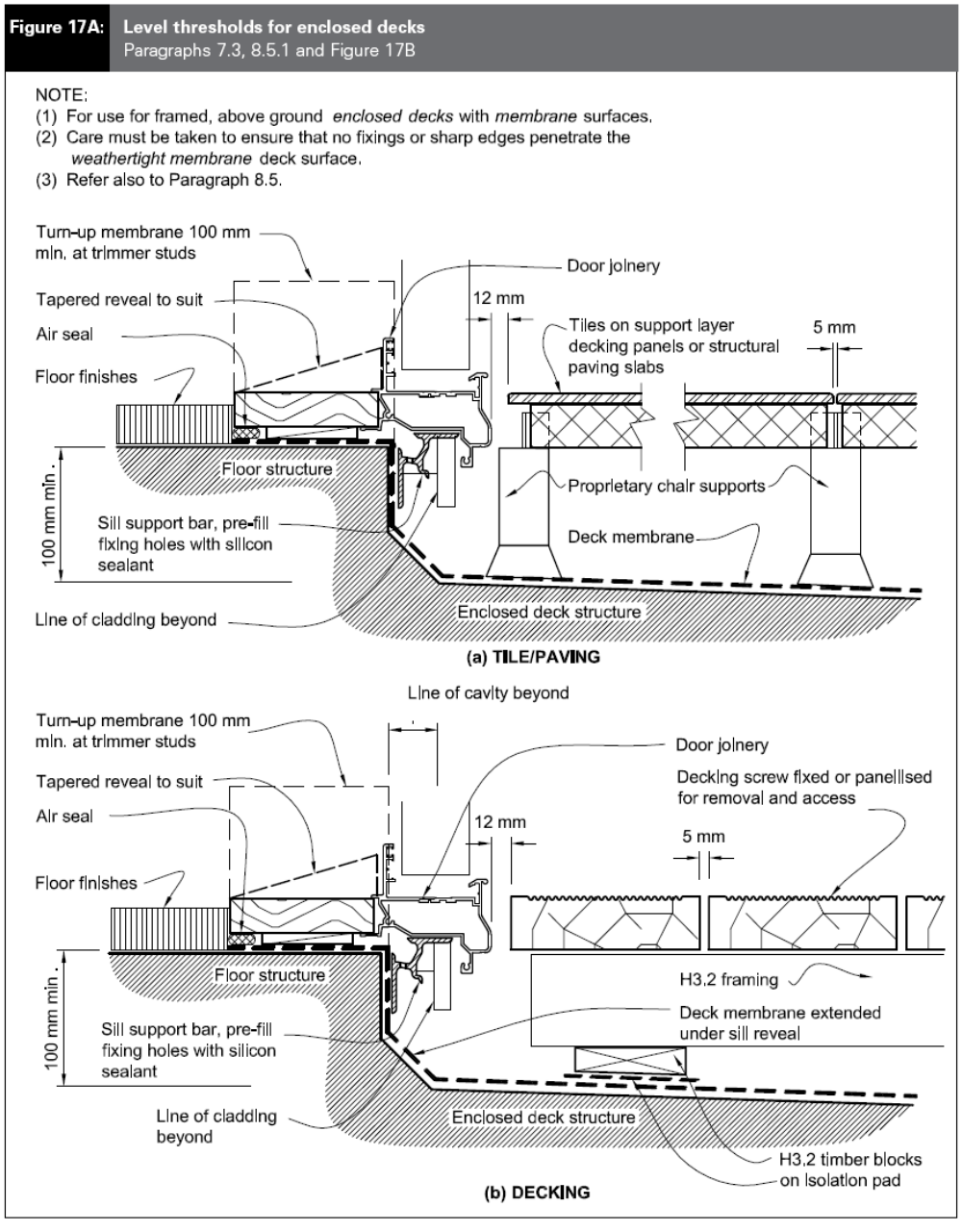



Note: Figure 73D, describes an alternative sill support detail for masonry veneer, which includes a poured concrete extension to the slab edge under the window or door and uses a sill tray flashing as detailed for direct fixed cladding situations.

Figure 73D: Masonry veneer details
Paragraph 9.2.5

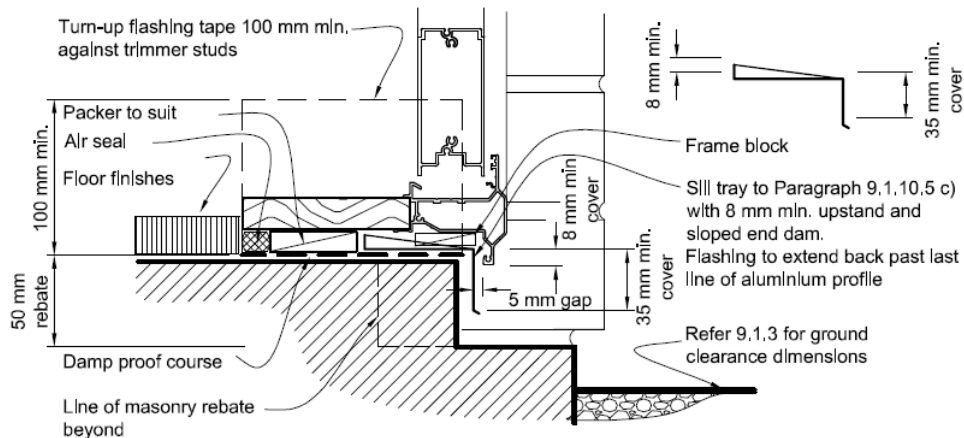

(h) MASONRY VENEER - DOOR SILL

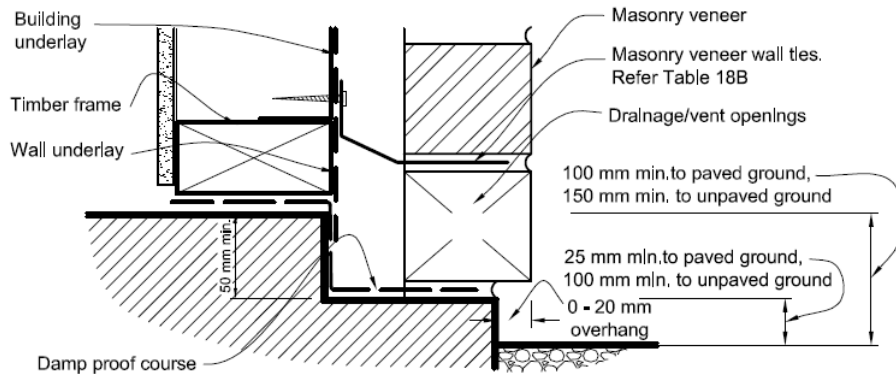

(i) MASONRY VENEER - FLOOR REBATE DETAIL

Errata 2
Dec 2011

Errata 2
Dec 2011



Step C2 – Position the Unit

- a. Before positioning the window or door unit into the opening ensure that, where applicable, that the sill corners have been fitted with corner soaker as described in *Clause 9.1.10.5 c*).

Check with your window manufacturer regarding the types of corner soaker used with their systems and that they are indeed applicable.

c) Mitred aluminium window and door sills, for both *cavity* and *direct fixed*, shall have a corner soaker fitted to the back of the sill/jamb joint and installed at point of manufacture. The soaker will be designed to act as a secondary device to prevent water ingress to the *building* in support of the primary mitre seals. Soaker materials shall be either uPVC, aluminium, polypropylene, high impact styrene or other semi rigid moulded polymeric material.

- b. Ensure the unit is positioned so that;

i) The unit is positioned 5mm forward of the exterior cladding line, as described in *Clause 9.1.10.2 d*),

d) For cavity fixed *claddings*, windows and doors shall finish against the *cladding*, except for flat fibre cement and ply *claddings* that require a 5 mm stand-off to allow for sealant weather seals between facings and *cladding* – eg, Figure 116.

ii) The interior linings finish in the correct positions,

iii) The unit is sitting correctly on the sill support bar,

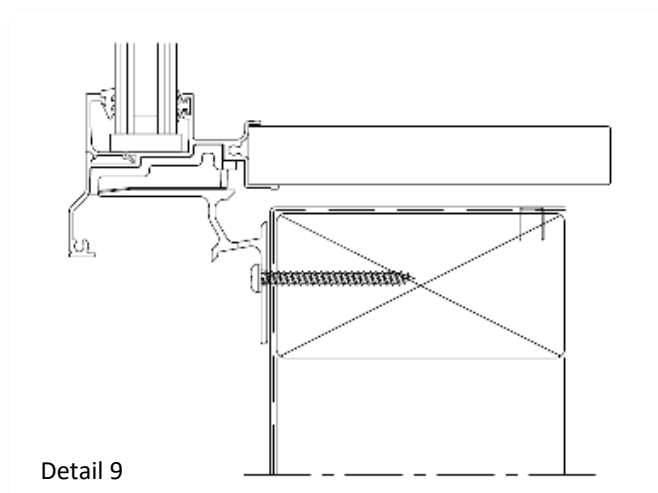

iv) Once the installation has been completed, check that the required cover over the exterior cladding as described in *Clause 9.1.10*, has been achieved.

After installation, the flange forming the window or door facing shall have an overlap to the surrounding *cladding* material or associated back *flashings* of

- a) For jambs – 10 mm minimum
- b) For sills – 8 mm minimum.

Amend 5
Aug 2011



Note: Traditionally a nominal clearance of 5mm is detailed between the window jamb liner and the framed opening. The purpose of this is i) to allow space for the application of an air seal and ii) to avoid water being drawn into or being held within the opening due to capillary action.

The industry now typically calls for an installation tolerance of 15mm (7.5mm each side) on the framed opening, to allow for flashing tapes etc.



Step C2a – Position the Unit – Full Height

Figure 17C, describes the sill details for full height window and door units for cavity construction. The positioning of the unit is essentially the same as described in Step C2 above.

Figure 17C: Door sills for cavity construction
Paragraph 9.1.10.5, Figures 73C, 85, 86, 91, 99, 116 and 128

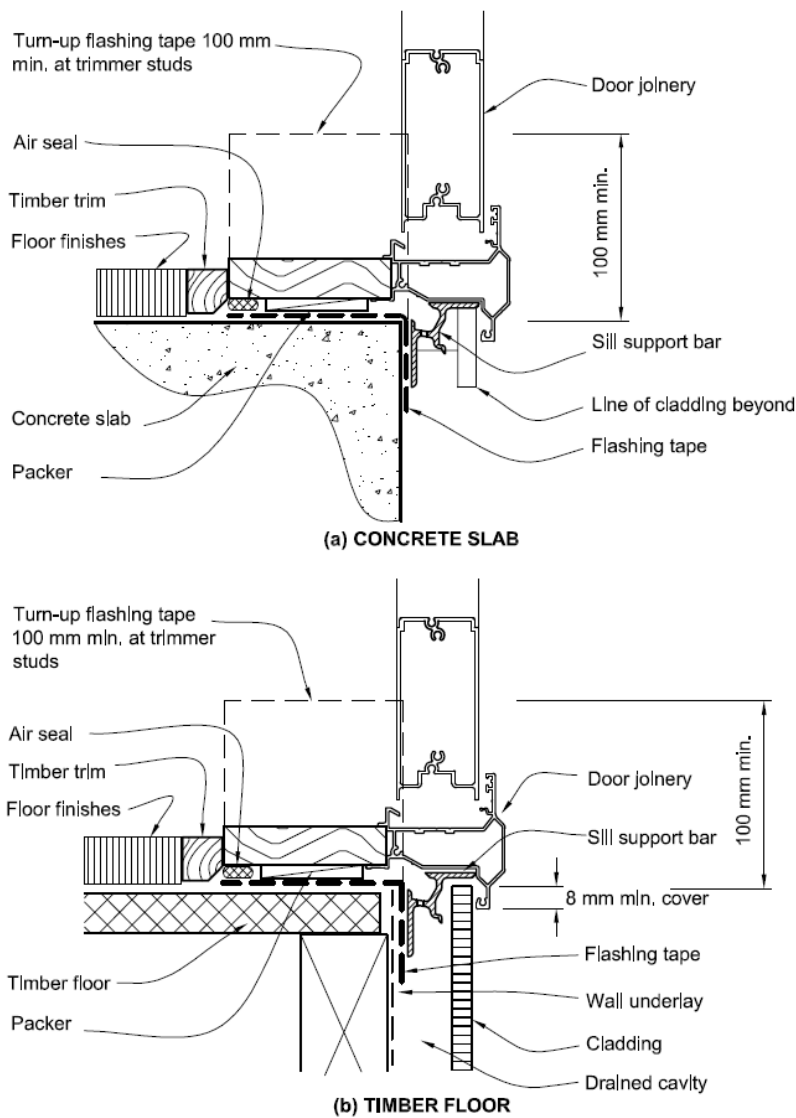

Amend 5
Aug 2011



Note: Ensure the correct sill support bar is selected for these details, as described on Pages 15 & 16, so that fixings are positioned appropriately.



Note: Some find the on-floor details described in Figure 17C to be undesirable. If so then a rebated sill detail will need to be designed for the situation. In this case the rebate becomes the threshold level, i.e. the floor level inside of the window or door is irrelevant to the Acceptable Solution.

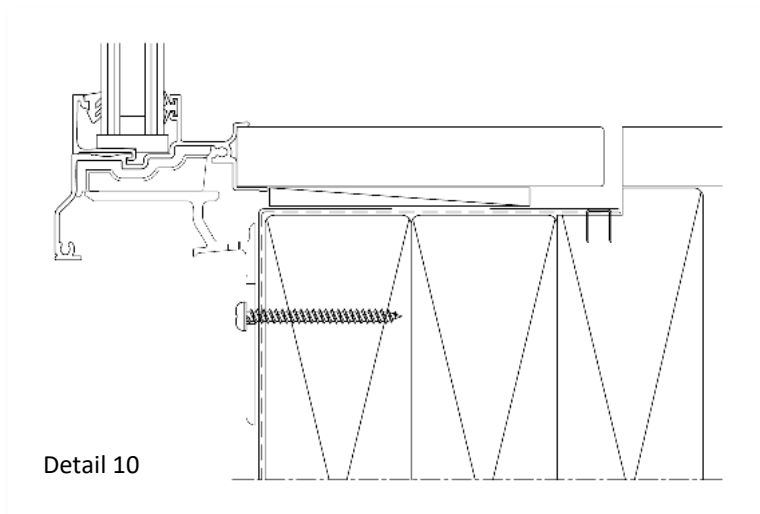

Rebated Timber Floor

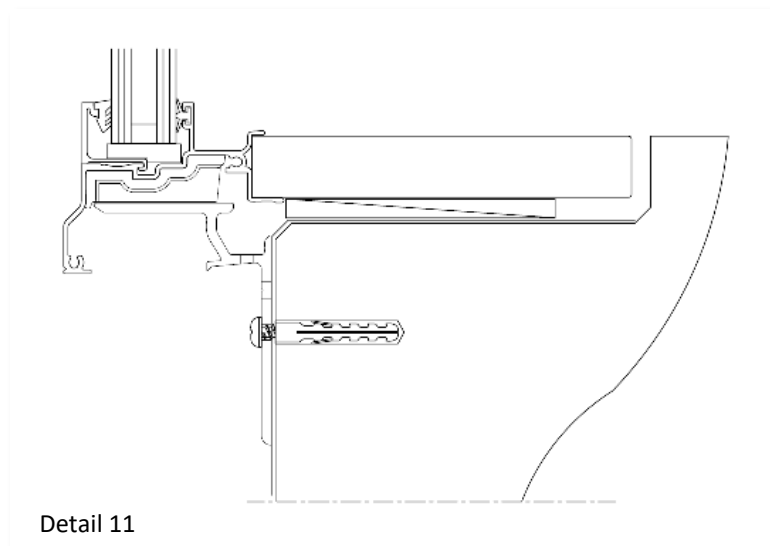

Rebated Concrete Floor



Step C3 – Fixing

- a. Insert flat packers between the wall framing and the window or door reveals at the head, sill and jambs at fixing points. **DO NOT use wedges.**
- b. Fix off the unit as described in *Clause 9.1.10.8.*

9.1.10.8 Attachments for windows and doors

Install windows and doors using pairs of minimum 75 x 3.15 galvanised jolt head nails or 8 gauge x 65 mm stainless steel screws, through reveals into surrounding *framing* at:

- a) Maximum 450 mm centres along sills, jambs and heads, and
- b) Maximum 150 mm from reveal ends.

Install packers between reveals and *framing* at all fixing points, except between head reveals and lintels.

Amend 5
Aug 2011

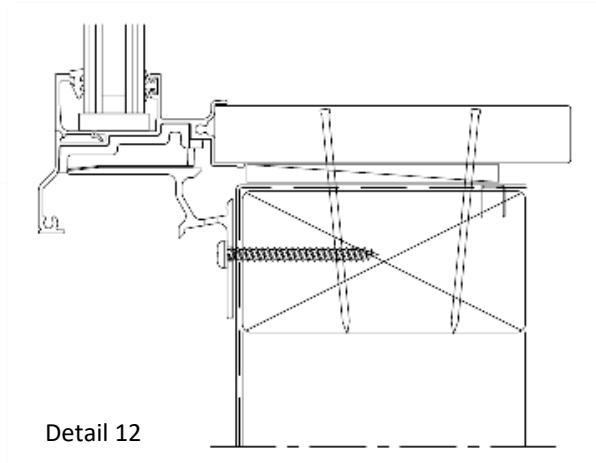

Note 1: This Clause describes the fixing method for typical windows and doors. Larger units or those subject to higher wind loads may require additional fixing. If in doubt, contact your window manufacturer to confirm.

Note 2: Reference is made to pairs of nails or screws. To clarify the reference is pairs of 3.15 nails and pairs of 8g screws.

- c. After fixing the unit in place, remove the packers from the head of the unit to allow any potential settlement of the building structure.

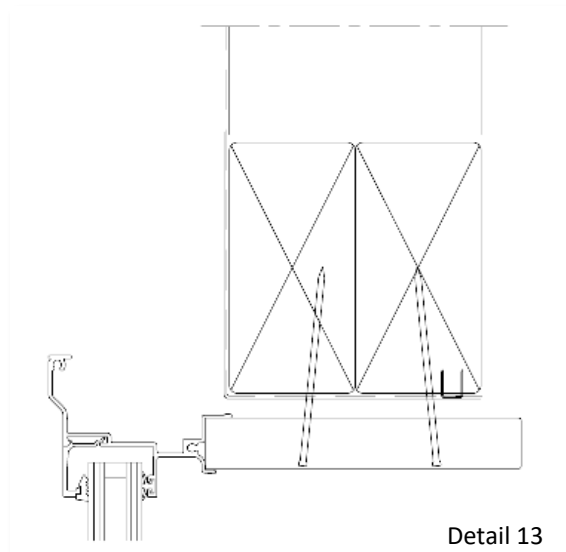



Step C3a – Fixing – Full Height

For full height units fixed to concrete floors replace the nail fixings with pairs of 8g x 65mm screws driven into nylon plugs or similar.

If the installer prefers to use masonry anchors, these can be substituted as noted on Page 15. Regardless of fixing type, ensure edge clearances, as recommended by the anchor supplier, are observed.

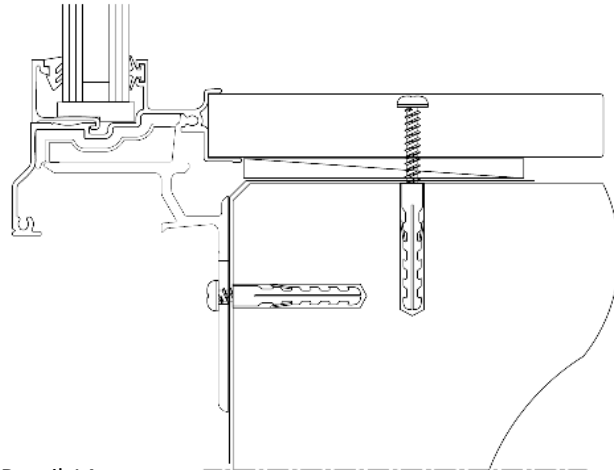

Detail 14



Note: Fixing holes into concrete should be pre-filled with sealant prior to the installation of the fixing as noted in Figure 17A (Page 17).

For timber floors, ensure the screw fixing is positioned a minimum of 20mm from the edge of the joist. This may require re-drilling of the sill support bar.

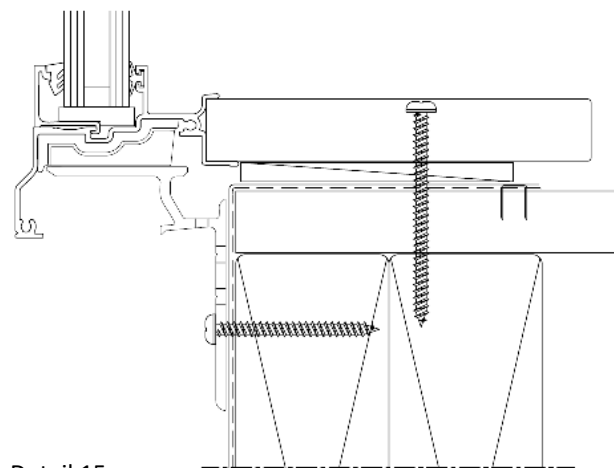

Detail 15



Step C4 – Air Seal

The Air Seal is designed to hold pressure in the trim cavity to enable pressure equalisation to occur. Typically, the Air Seal is a low expansion polyurethane foam installed over a PEF backing rod, as described in *Clause 9.1.6*.

The detail drawings contained within E2/AS1 show the air seal as a single entity. Please note *Clause 9.1.6 b)*.

9.1.6 Air seals

Window, door and other penetration openings shall be provided with flexible *air seals* to minimise the risk of airflows carrying water into the *building wall*. The *air seal* shall be:

- a) Provided between the reveal or frame and the wrapped opening (for example of use, refer to Figure 81),
- b) Installed over a closed cell polyethylene foam (PEF) backing rod, or similar
- c) Made of:
 - i) self-expanding polyurethane foam, or
 - ii) sealant complying with:
 - a. Type F, Class 20LM or 25LM of ISO 11600, or
 - b. low modulus Type II Class A of Federal Specification TT-S-00230C.

Amend 5
Aug 2011

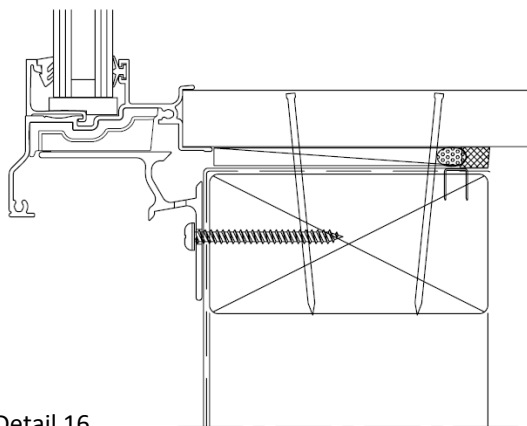

Detail 16



Note: *Clause 9.1.6 makes this comment regarding air seals.*

COMMENT:

Some sealants can react with bitumen based *flashing* tape, preventing full curing of the sealant. Where necessary, consult sealant manufacturers for application requirements.

Backing rods are used for sealant and for self-expanding polyurethane foam as there is a danger foam will expand to the outside of the *wall* and form a moisture bridge to the interior.

For further information refer to ASTM C1330 for backing rod material performance.



Step C5 – Head Flashing

Clause 9.1.10.4 describes the basics of head flashings.

9.1.10.4 Head flashings

Head flashings shall be in accordance with Paragraph 4.6.1.6 and Table 7, unless specifically shown otherwise, and shall:

- a) Direct water to the outside of the wall cladding, and
- b) Finish to the window head with clearance dimensions shown in Figure 71

Specifically, paragraphs d) and e) apply to cavity construction.

d) For wall claddings on cavity walls:

- i) incorporate 10 mm turn-ups as stop-ends, terminating at the inside face of the cladding so they do not pass through the cladding, and
- ii) permit ventilation of the drained cavities above, by the installation of cavity base closers as shown in Figure 66.

e) For Very High and Extra High wind zones, have sealant installed between underside of head flashing and top edge of window head flange – refer Figure 71 (c) .

COMMENT:

Stopends are useful to prevent water moving past the ends of head flashings. However, additional problems of weatherproofing occur where the stopend penetrates the cladding.

Detail a) from Figure 85, shows the typical head flashing set out and prescribed dimensions.

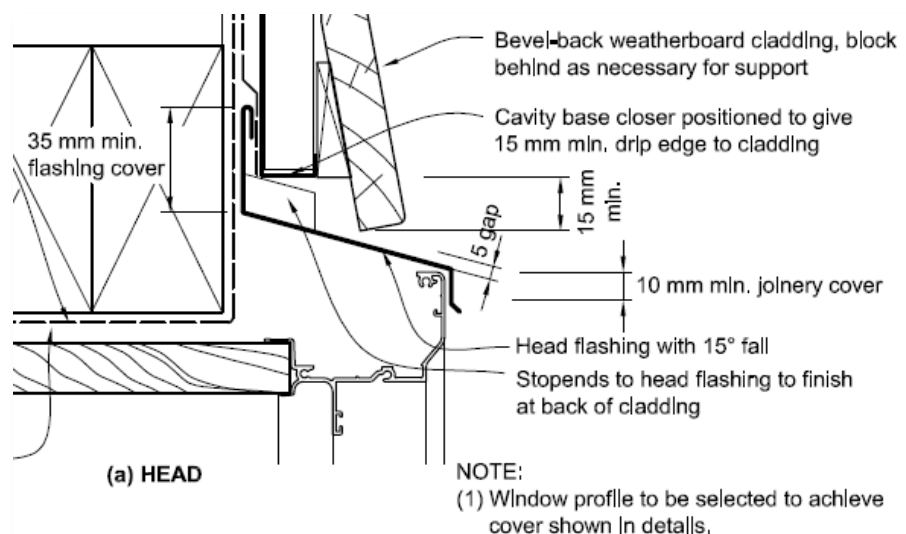

Table 7 describes the upstand cover required by window head flashings.

Table 7: continued		Metal flashings – general dimensions Paragraphs 4.6, 4.6.1.1, 4.6.1.2, 4.6.1.3, 4.6.1.4, 4.6.1.5, 4.6.1.6, 4.6.1.7, 5.1, 6.4, 6.5, 7.4.4, 8.3.8, 9.1.3, 9.1.10.2, 9.1.10.4 and 9.4.5.3				
Membrane roofs and decks	Lap under <i>cladding</i> above	115 min.				Figures 18, 62a, c, 64b
Type	Description	All (1)	Situation 1 (2) minimum mm	Situation 2 (3) minimum mm	Situation 3 (3a) minimum mm	Figure reference (as example)
Heads	Head <i>flashing</i> slope	15° min.				Eg. Figure 81a
	Lap under <i>cladding</i> above	35 mm min.			60 mm	Eg. Figure 81a
	Anti-capillary gap to <i>cladding</i>	5 mm				Eg. Figure 81a
	Total upstand	40 mm min.				

The most common form of window or door head flashing is the extruded aluminium version, chosen primarily because of its consistent dimension and ease of installation. Those supplied by WANZ members are available to suit a wide range of claddings. These extruded flashings are designed to provide a nominal 5mm gap between the back of the flashing and the face of the window.

With Amendment 10 to E2/AS1 the design of the vertical upstand of the flashing has been increased to 65mm to comply with *Table 7* and *Clause 4.5.1 2)*.

However, these do not comply for use in an Extra High Wind Zone, unless they are provided with a hook or hem to the upper edge of the flashing.

4.5.1 Edge treatments for flashings

Flashings shall be to the dimensions shown throughout this Acceptable Solution.

Exposed bottom edges of *flashings* shall be folded to a *kick-out* or a *bird's beak* as shown in Figure 5.

For Low, Medium, High and Very High *wind zones*, *flashing upstands* shall have either:

- 1) A *hem* or *hook* to Figure 5, with upstand dimensions as shown throughout the document, or
- 2) No *hooks* or *hems*, and *flashing upstand* dimensions increased by 25 mm beyond those shown.

For Extra High *wind zones*, *hooks* and *hems* shall be used, and *flashing upstand* dimensions increased by 25 mm beyond those shown in Table 7 or elsewhere in the document.



Note: E2/AS1 Amendment 10 does not prescribe the offset of the head flashing from the face of the window flange. As noted above WANZ members offer head flashings designed to provide a nominal 5mm gap between the flashing and the window is achieved, similar to that shown below the cladding. The gap helps to avoid capillary action drawing water over the head of the window.

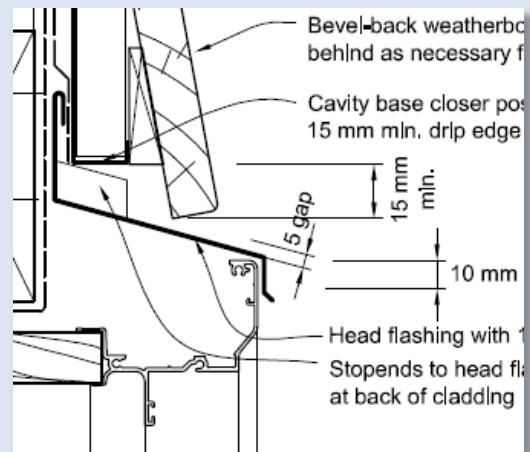

It is industry standard to extend the length of the head flashing 20mm past each side of the window, i.e. window width +40mm.

In cases where jamb scribers are used, these are considered as a part of the window width and therefore the +40mm is added to the overall scriber dimension.

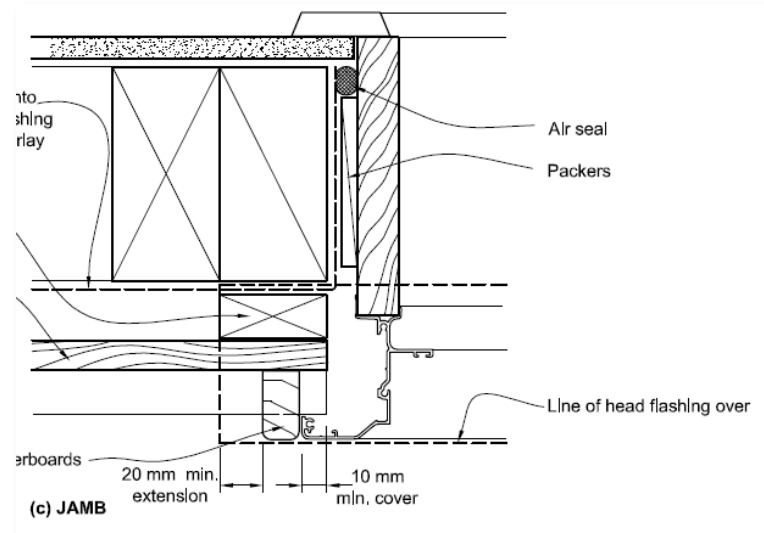

This is described in each of the window details shown within E2/AS1 Amendment 10.

Because of the difficulty in folding extruded aluminium head flashings, the stop ends, described in Clause 9.1.10.4 d) i), can be supplied as an applied injection moulded plastic item which is fitted on site.

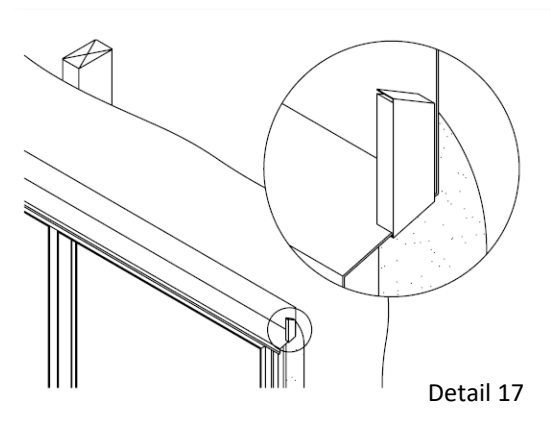
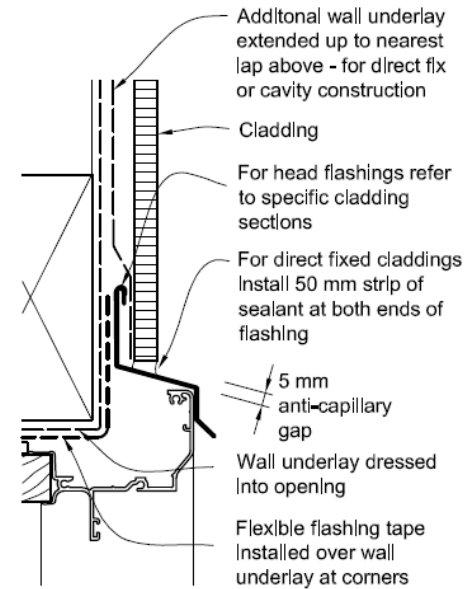

Figure 71, describes the general set out of the head flashing and the wall underlay options. Whilst these details are shown as direct fix situations the same will apply to cavity construction.

Figure 71: General sealing of head flashing
Paragraphs 9.1.7, 9.1.10.3 and 9.1.10.4

NOTE: May also use *wall underlay* lapped over flashing upstand in lieu of *flexible flashing tape*. Refer cladding window details, for example Figure 115.



(a) METAL HEAD FLASHING - WITH ADDITIONAL UNDERLAY OPTION

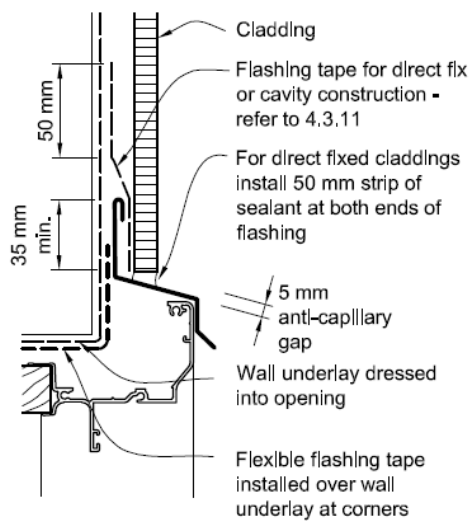

(b) METAL HEAD FLASHING WITH FLASHING TAPE OPTION

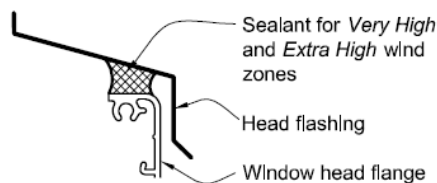

(c) METAL HEAD FLASHING SEALANT FOR VERY HIGH AND EXTRA HIGH WIND ZONES

Amend 5
Aug 2011



Note: Detail (c) shows sealant between the top of the window or door flange and the underside of the head flashing. Use of a closed cell foam tape in this case might simplify the application. The detail applies to Very High and Extra High wind zones only.



Note: Windows or doors that extend to the soffit do not require a head flashing but instead will have a trim fitted as shown in Figure 8A f).

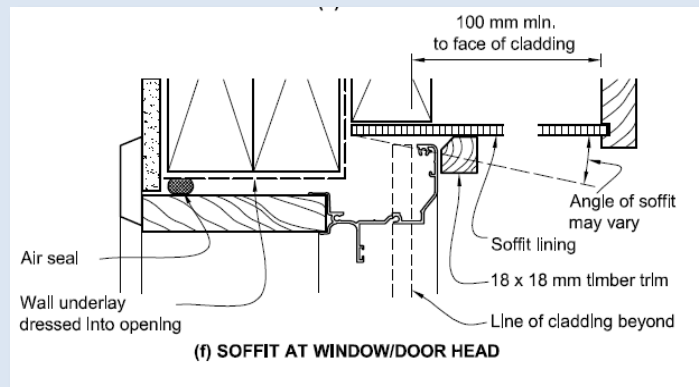

Errata 2
Dec 2011

Amend 2
Jul 2005

Amend 5
Aug 2011



Supplementary Detail 1

In some instances, where a window or door unit is to finish against the soffit of the building, then the Steps described in the preceding pages can be difficult to achieve. The following modifications to these Steps could be made to ease the installation process...

Detail 1.1 – Full Height to Soffit

Step C1b – Sill Support

The sill support bar options, for window or door units extending to the floor, are limited to only the face mounted Heavy-Duty bar, however its fitment to the slab varies from the steps described previously.

Rather than setting and levelling the platform of the sill support bar at 5mm above the floor level, the platform is set at the **same** height, as indicated by RLx in Detail 18. This means that the location brackets usually supplied with the sill support bar cannot be used to hold the bar whilst it is levelled.

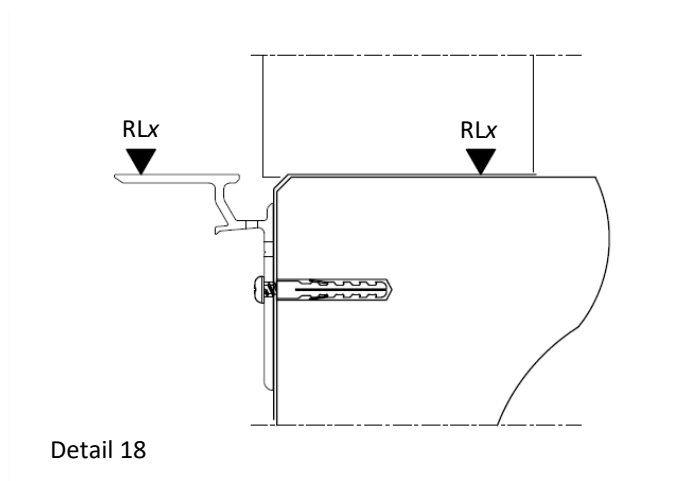

Fixings etc. are as previously described in Step C1, Fixing Options, on Page 15.

Step C2b – Position the Unit

Positioning of the window or door unit is essentially as described in Steps C2 & C2a, on Pages 19 & 21 respectively, except as follows;

- a. Check that the unit is sized so that the dimension from the underside of the sill reveal to the upper edge of the head facing, is a nominal 10mm less than the dimension from the floor to the underside of the soffit.
- b. Position the unit into the opening resting on the floor/sill support bar platform.

- c. Lift the unit so that there is a nominal 5mm gap (use a packer to set the gap) at the top of the window or door, between the upper edge of the facing and the underside of the soffit.

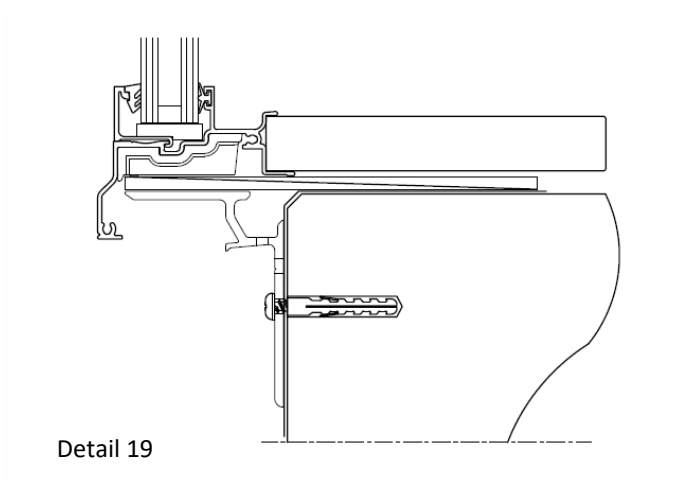

- d. Pack the sill, ensuring that the packers extend across **both** the floor and the sill support bar platform.

Step C3b – Fixing

For full height units fixed to concrete floors replace the nail fixings with 8g x 65mm screws driven into nylon plugs or similar.

If the installer prefers to use masonry anchors, these can be substituted as noted, on Page 15. Regardless of fixing type, ensure edge clearances, as recommended by the anchor supplier, are observed.

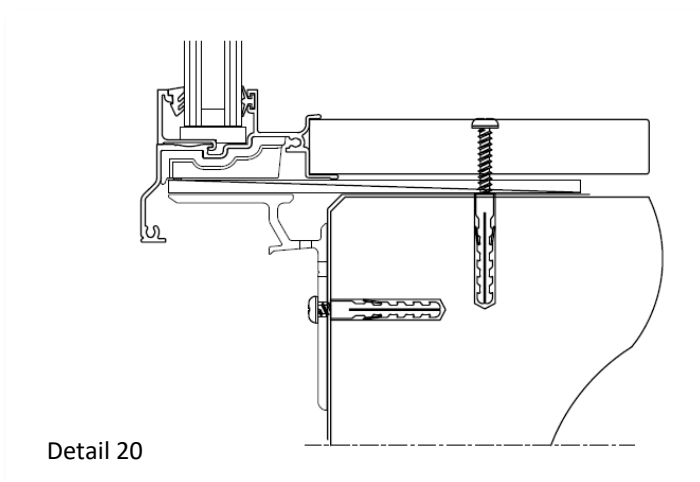

Step C4 – Air Seal

Apply the Air Seal as described in Step C4 on Page 25.

Step C5b – Head to Soffit

After ensuring all surfaces are clean (and primed where necessary), seal the gap between the window or door facing and the soffit with a good quality MS sealant.

Step C5, from Page 26, describes the design and installation of the head flashing for a window or door unit. The primary function of any head flashing is to deflect any water falling or running from above away from a potential entry point, at the head of the unit. This is the first D (*deflection*) of the weathertightness principles.

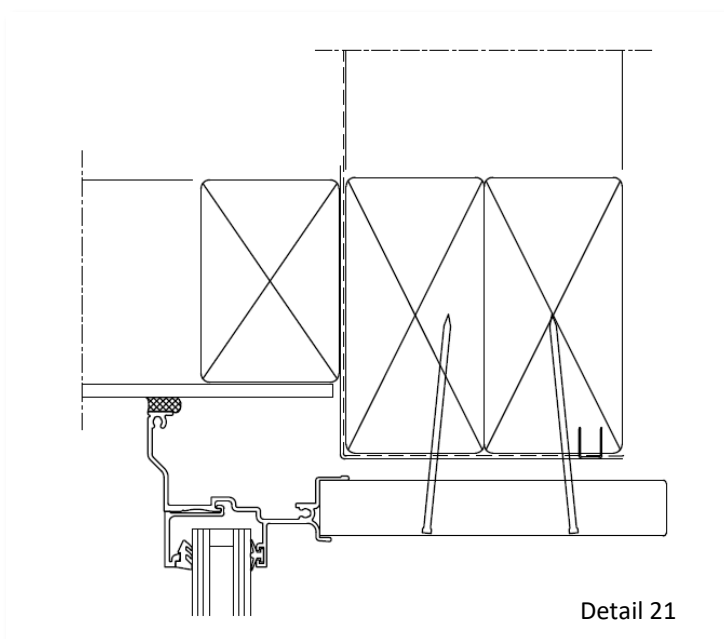

Note: In this case, where there is no falling/running water, and because of the impracticality of fitting a head flashing in this environment, it is the seal that protects the head from water ingress. This is described in Figure 8A f) of the Acceptable Solution.

Before proceeding, the building designer must satisfy themselves that the detail is robust enough to satisfy the conditions specific to their project.

Detail 1.2 – Part Height to Soffit

Step C1c – Sill Support

The sill support for window units sitting on a sill trimmer and extending to the soffit varies from the steps described previously.

Rather than setting and levelling the platform of the sill support bar at 5mm above the sill trimmer, the platform is set at the **same** height, as indicated by RLx in Detail 22. This means that the location brackets usually supplied with the sill support bar cannot be used to hold the bar whilst it is levelled.

Fixings etc. are as previously described in Step C1, Fixing Options, on Page 15.

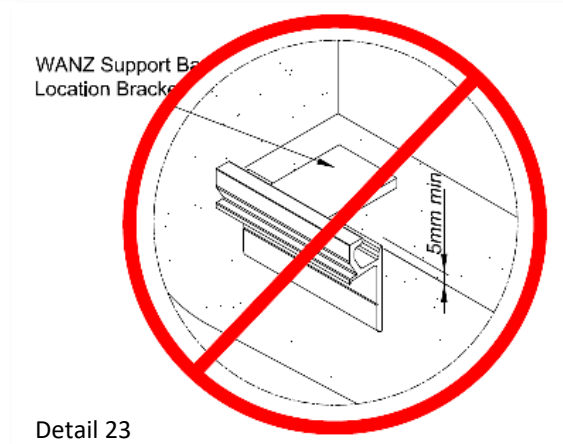
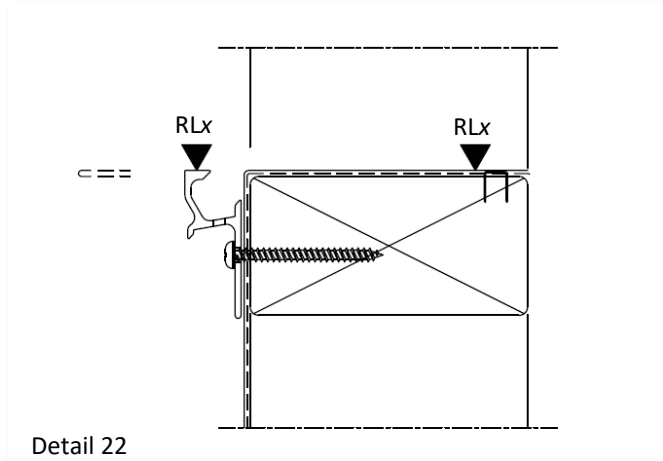

Step C2c – Position the Unit

Positioning of the window unit is essentially as described in Steps C2 on Page 19, except as follows;

- a. Check that the unit is sized so that the dimension from the underside of the sill reveal to the upper edge of the head facing, is a nominal 10mm less than the dimension from the floor to the underside of the soffit.

- b. Position the unit into the opening resting on the floor/sill support bar platform.
- c. Lift the unit so that there is a nominal 5mm gap (use a packer to set the gap) at the top of the window or door, between the upper edge of the facing and the underside of the soffit.
- d. Pack the sill, ensuring that the packers extend across **both** the floor and the sill support bar platform.

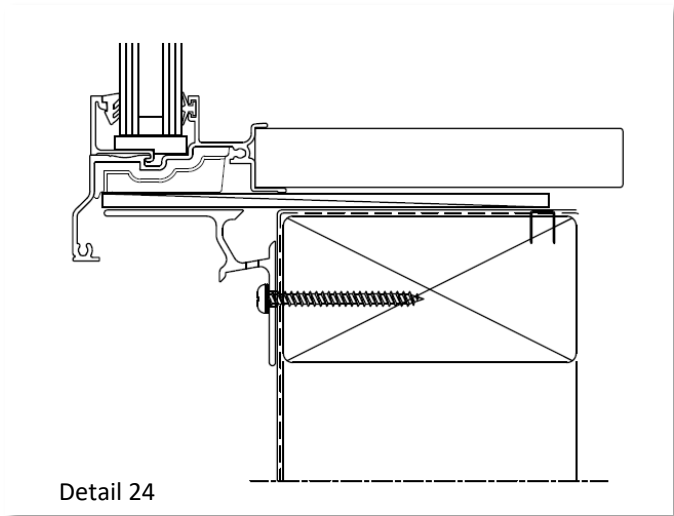

Step C3 – Fixing

Fix the window as described in Step C3 on Page 23.

Step C4 – Air Seal

Apply the Air Seal as described in Step C4 on Page 25.

Step C5c – Head to Soffit

After ensuring all surfaces are clean (and primed where necessary), seal the gap between the window or door facing and the soffit with a good quality MS sealant.

Step C5, from Page 26, describes the design and installation of the head flashing for a window or door unit. The primary function of any head flashing is to deflect any water falling or running from above away from a potential entry point, at the head of the unit. This is the first D (*deflection*) of the weathertightness principles.

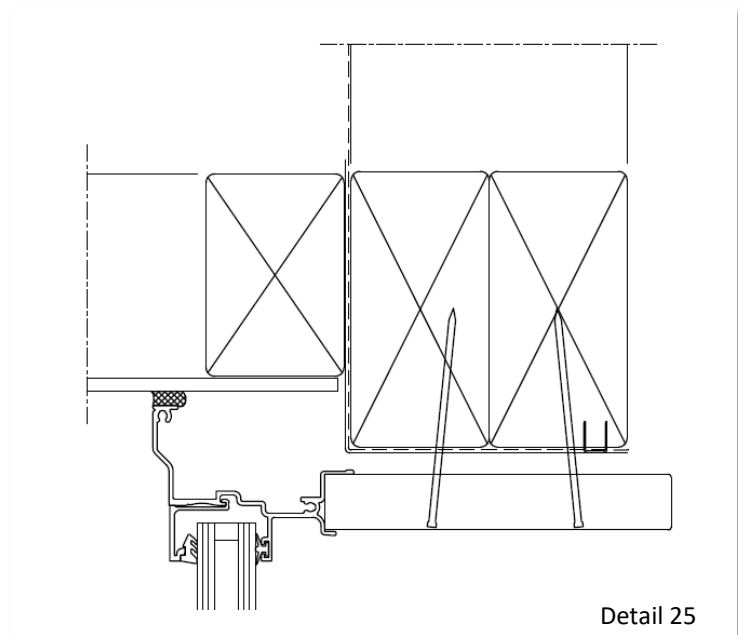

Detail 25



Note: In this case, where there is no falling/running water, and because of the impracticality of fitting a head flashing in this environment, it is the seal that protects the head from water ingress. This is described in Figure 8A f) of the Acceptable Solution.

Before proceeding, the building designer must satisfy themselves that the detail is robust enough to satisfy the conditions specific to their project.



WANZ Components – Cavity Construction

Components

Head Flashing

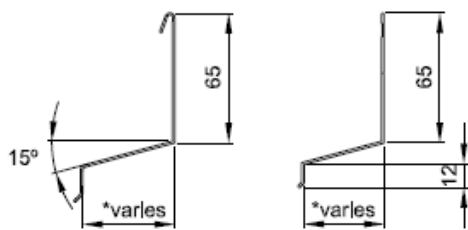

For Extra High Wind Zones

Material: Extruded Aluminium
 *Note: Dimension varies with cladding type
 Available in 5mm increments

WANZ Head Flashing End Cap



Material: Moulded Polypropylene

*Note: These parts form part of the window system and should be supplied by your window manufacturer.

WANZ Support Bar Selection

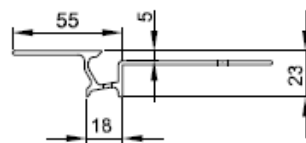
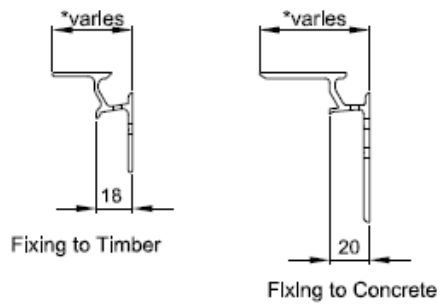

Material: Extruded Aluminium
 Punched drainage & fixing holes

WANZ Support Bar Location Bracket

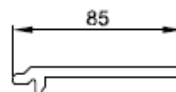

Material: Moulded Polypropylene
 Length: 60mm

Cavity Construction Typical Details

Figure 73C: Masonry veneer window and door installation
 Paragraphs 9.2.4, 9.2.6 and 9.2.9

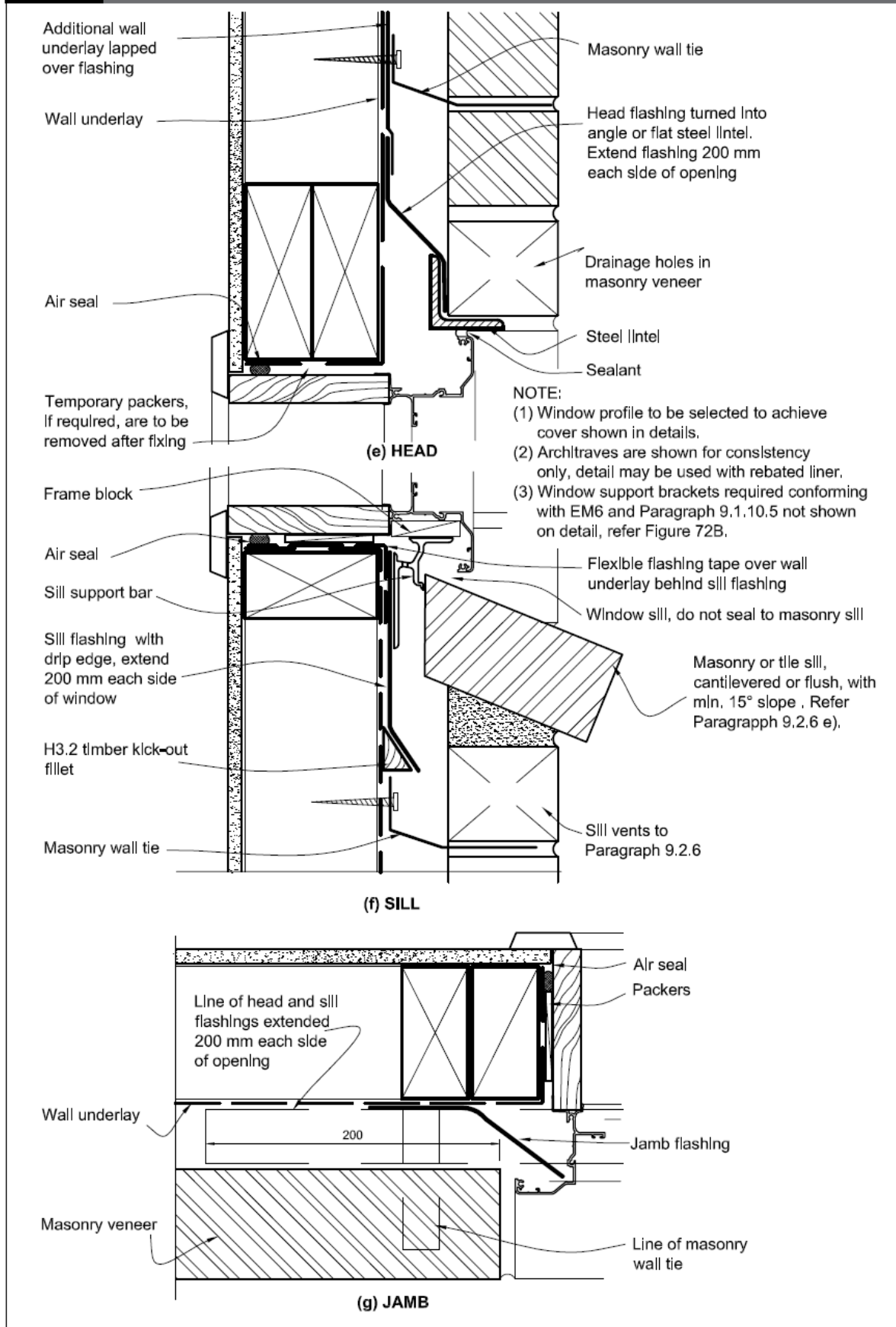

Figure 73D: Masonry veneer details
Paragraph 9.2.5

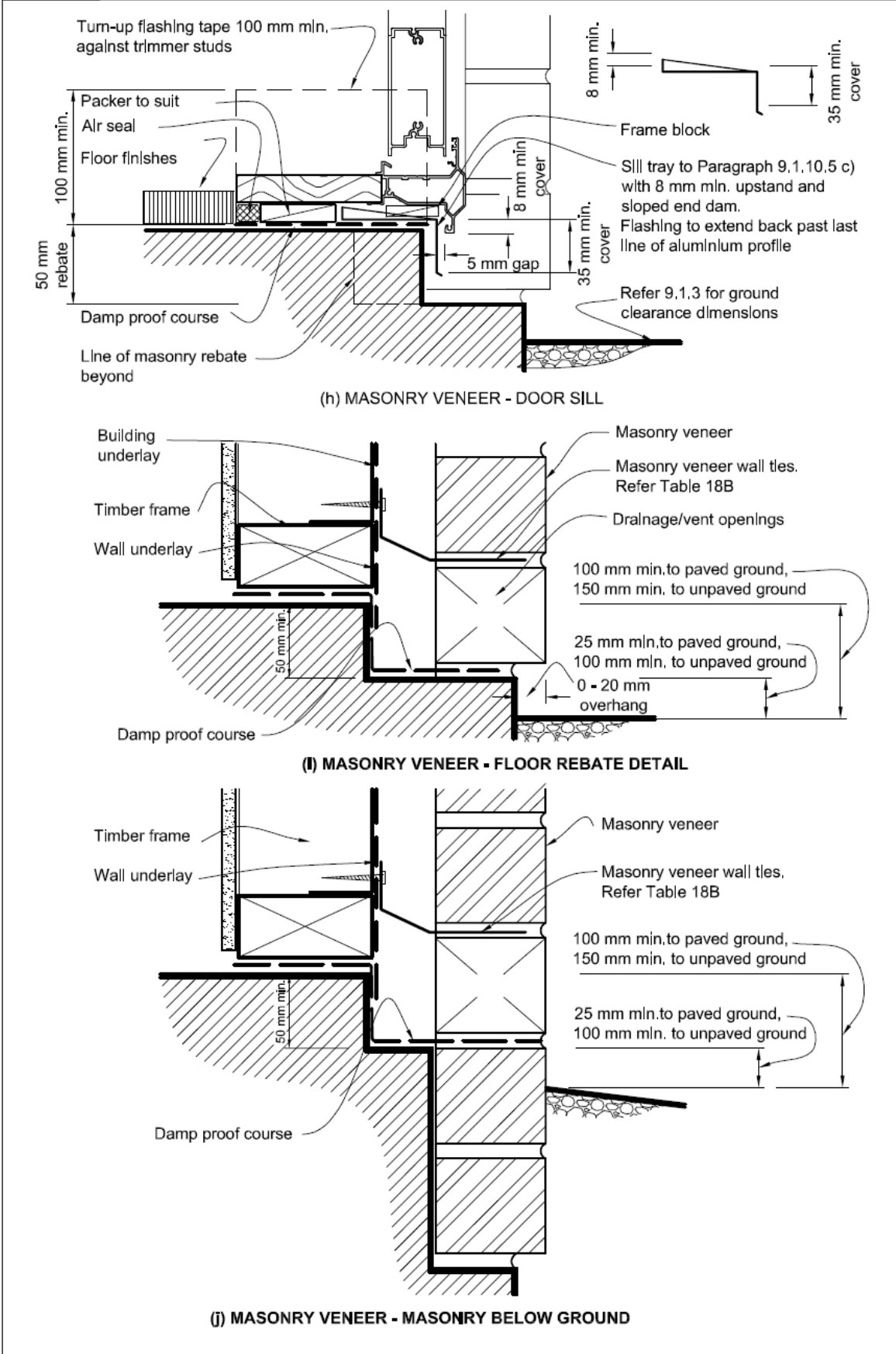

Figure 76: Windows and doors in stucco cladding
Paragraph 9.3.10, Figure 72B

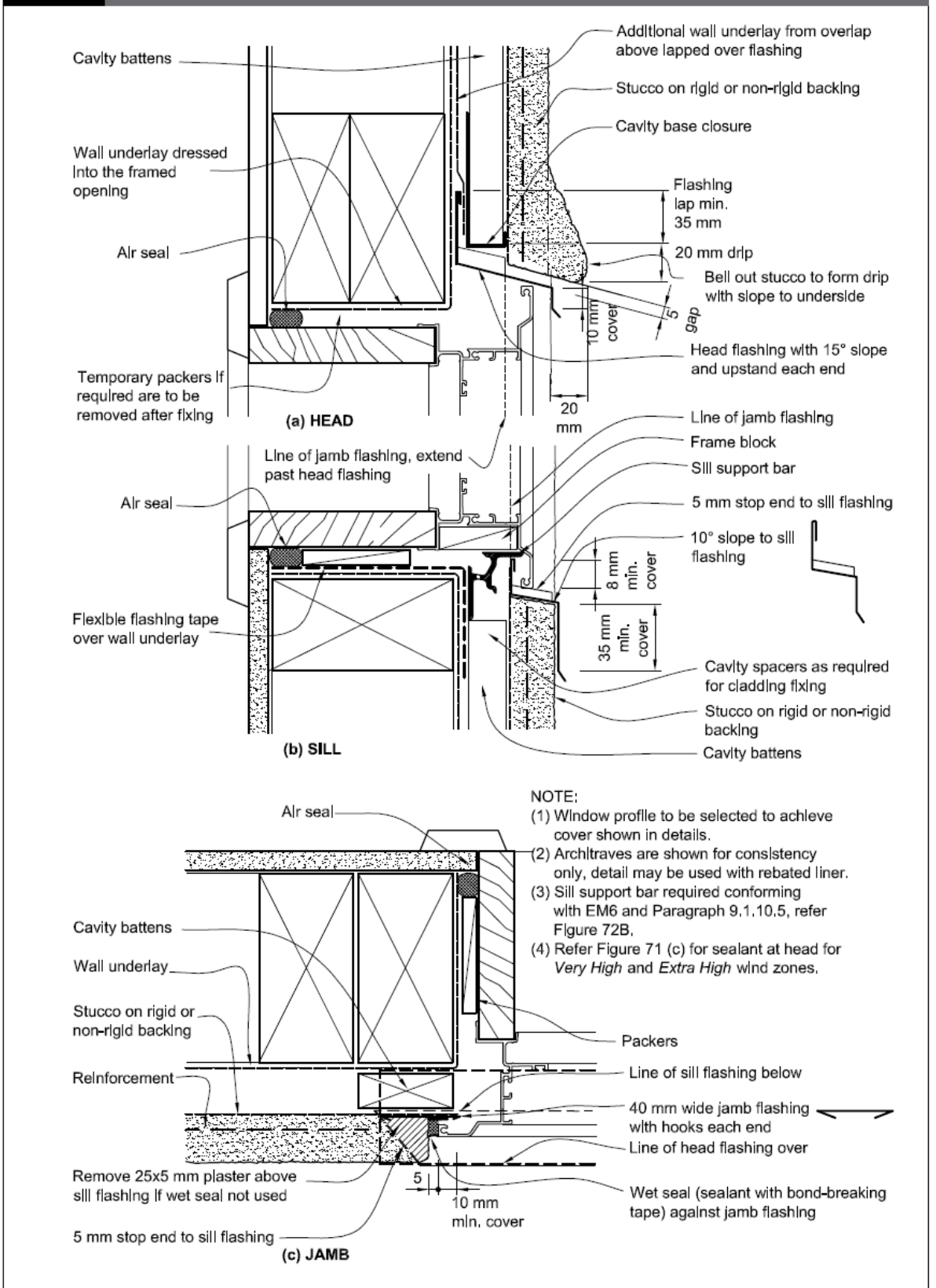

Figure 85: Windows and doors for bevel-back weatherboards on cavity
Paragraph 9.4.7

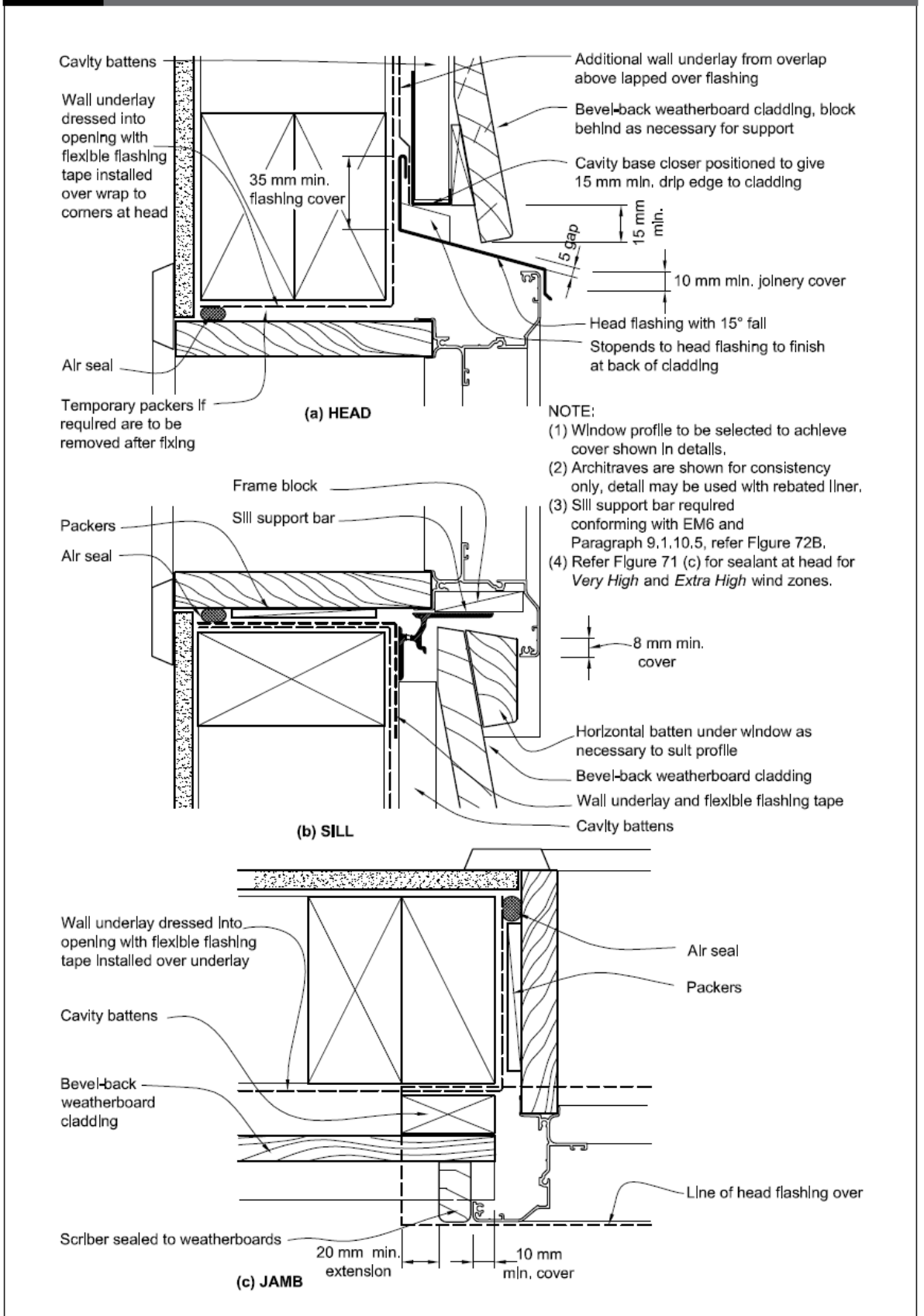

Figure 86: Windows and doors for rusticated weatherboards on cavity
Paragraph 9.4.7

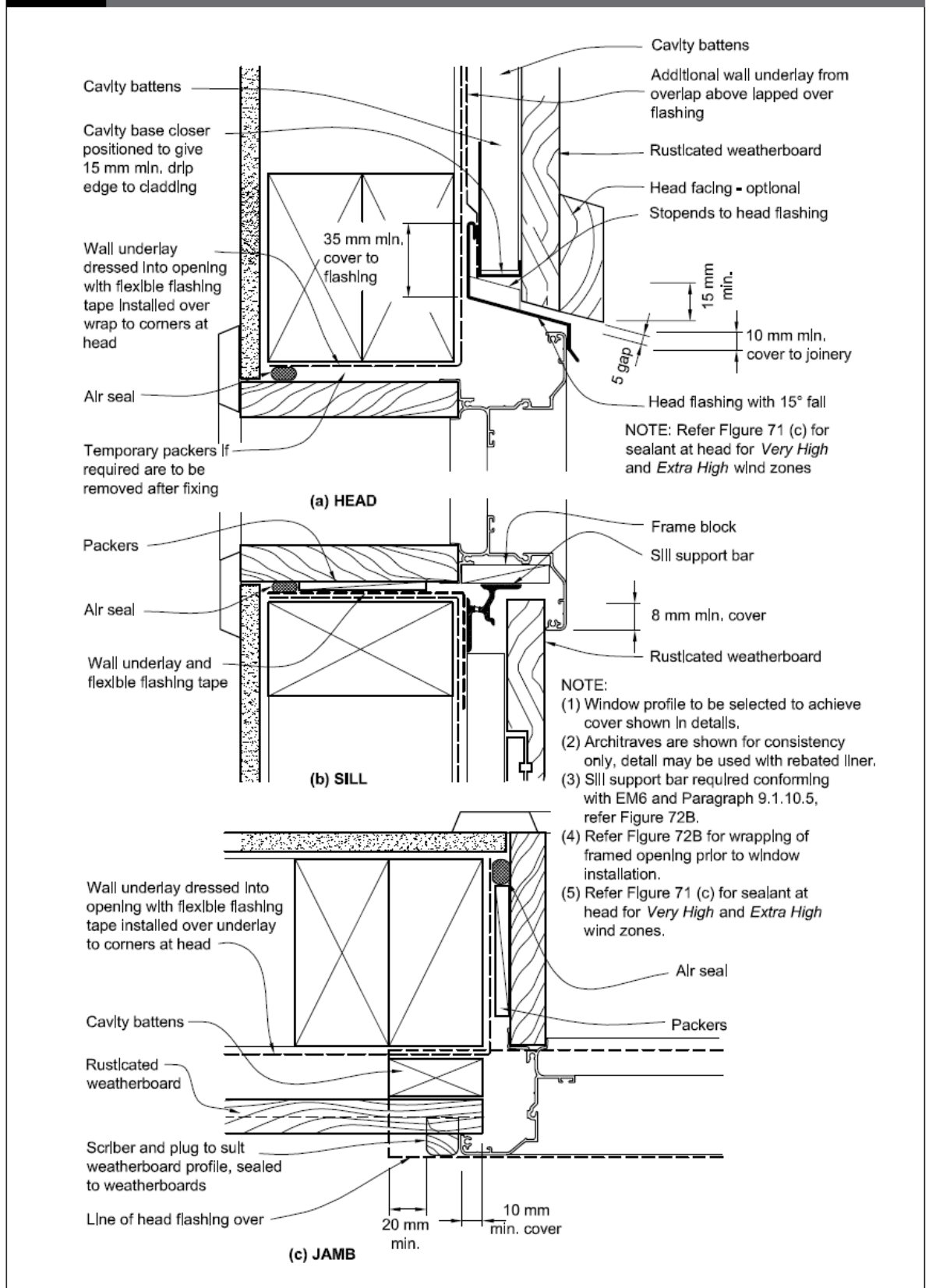

Figure 91: Windows and doors in fibre cement weatherboards on cavity
Paragraph 9.5.4.2

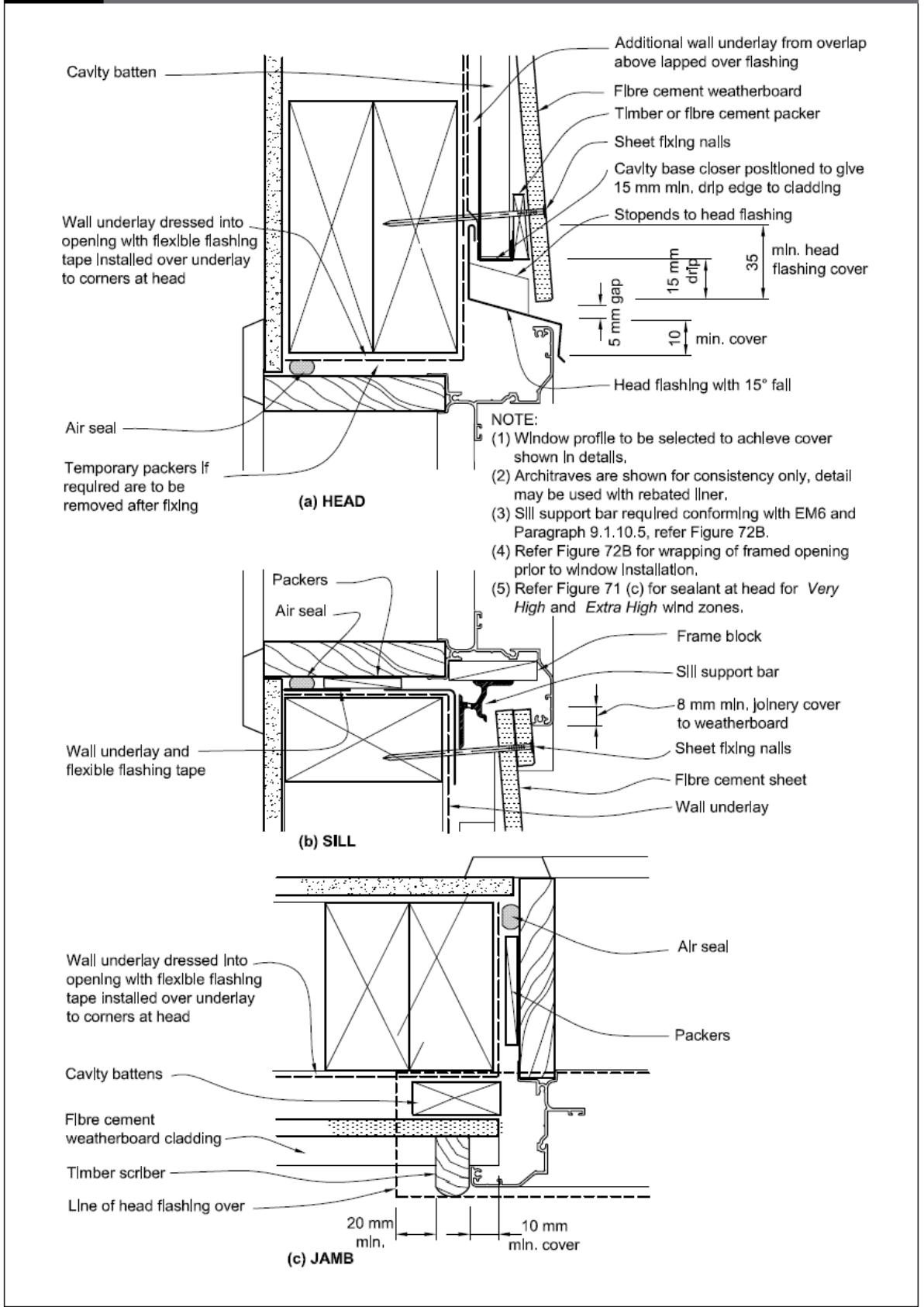

Figure 99: Windows and doors for horizontal profiled metal on cavity
Paragraph 9.6.9.7

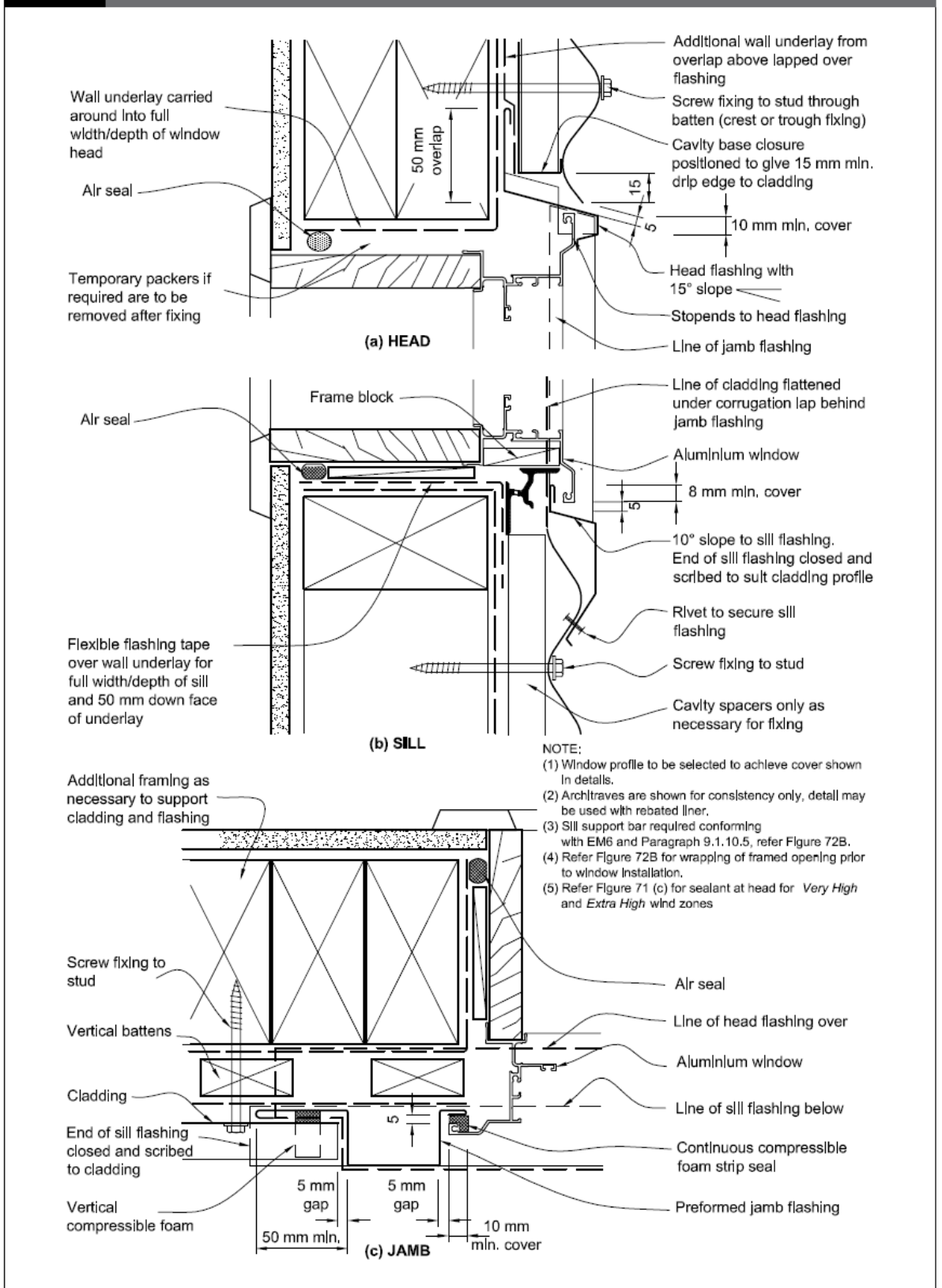

Figure 116: Windows and doors for fibre cement sheet and flush-finished fibre cement on cavity
Paragraph 9.7.6

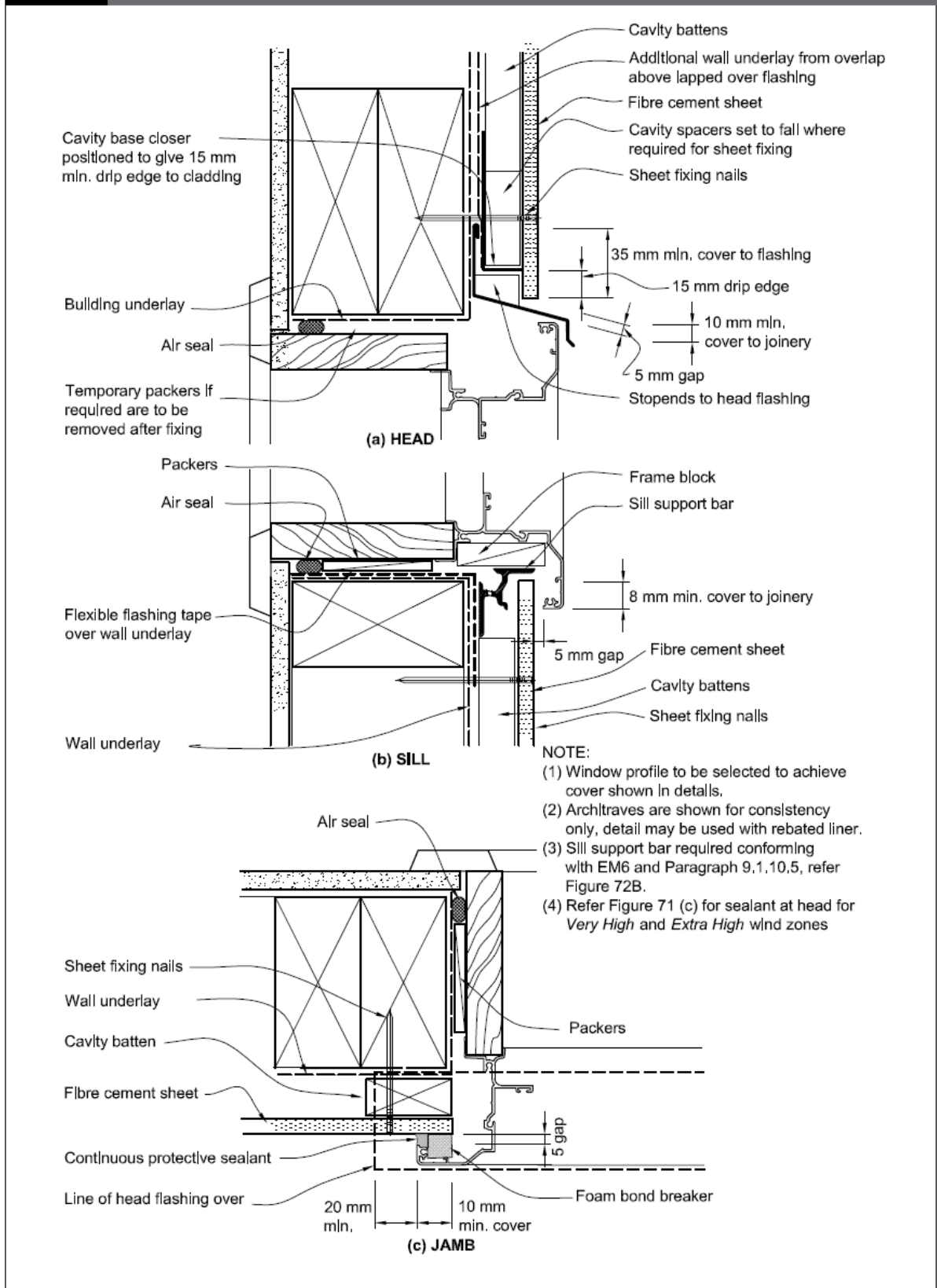
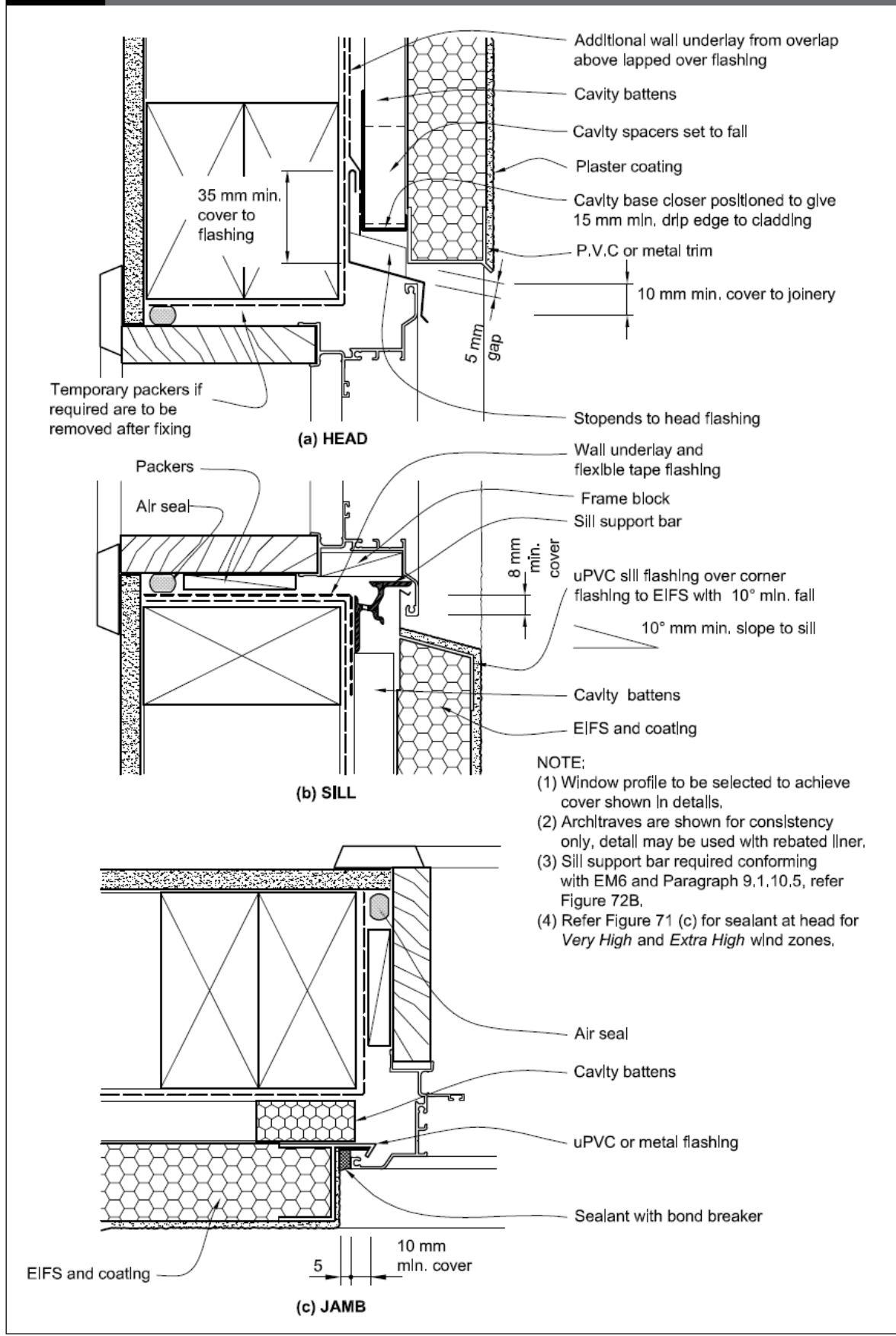

Figure 128: Windows and doors in EIFS
Paragraph 9.9.9



Direct Fix Claddings

Clause 9.1.10.2 describes the basics of window installation for direct fixed wall claddings.

9.1.10.2 Treatment of opening

- a) Treatment of the window openings for *direct fixed wall claddings* shall be as shown in Figure 72A.
- b) For *direct fixed claddings*, windows and doors shall have a 5 mm stand-off of the flange to the *cladding* to allow for air intrusion to the trim cavity for pressure equalisation. Note that this gap is sealed or trimmed down the jambs, but left open along the sill.



Step D1 – Sill Tray Flashing

Clause 9.1.10.5 a) describes the requirements of the Sill Tray Flashing in terms of compliance with E2/AS1. The use of flat sill tray flashings is quite a departure from the previous sloping version. To compensate the design of the flashing has been reviewed. There are some important points to note;

- a. The sill tray flashing is to extend beyond the inside line of the aluminium window or door frame, including the condensation channel.
- b. The sill tray flashing is to have an 8mm minimum upstand to the inside edge.
- c. The sill tray flashing is to have a minimum 35mm cover on the cladding and is to extend the full width of the trim opening.
- d. The sill tray flashing requires forward sloping end dams.
- e. The sill tray flashing is to extend the full width of the opening

9.1.10.5 Window and door sills

- a) *Direct fixed claddings* shall have
 - i) sill tray flashings as shown in Paragraphs 9.2 to 9.9 for each *cladding* type. The sill flashing shall extend back past the condensation channel of the window. Ensure flat sill trays do not slope backwards. The 5 mm gap between the window facing and sill tray must not be sealed.
 - ii) *direct fixed* door sills, installed as for windows, and as shown in Figure 17D.

The WANZ extruded aluminium sill tray flashings, are described on the Components page (Page 65) include each of the above features and also include a rear fixing tag to ease installation.

Also available is an injection moulded stop end which avoids the difficulties in folding extruded aluminium.

The stop end is snapped off to the correct length and is sealed in place on to each end of the tray.

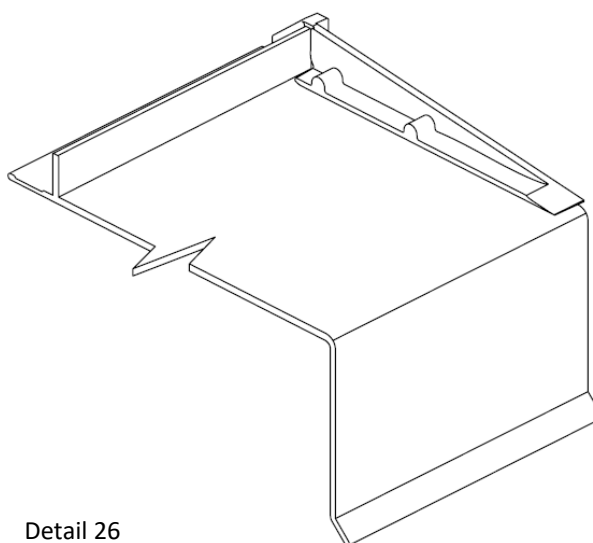

Detail 26

Figure 72A describes the general arrangement of the sill for a window installed into a wall with direct fixed claddings.

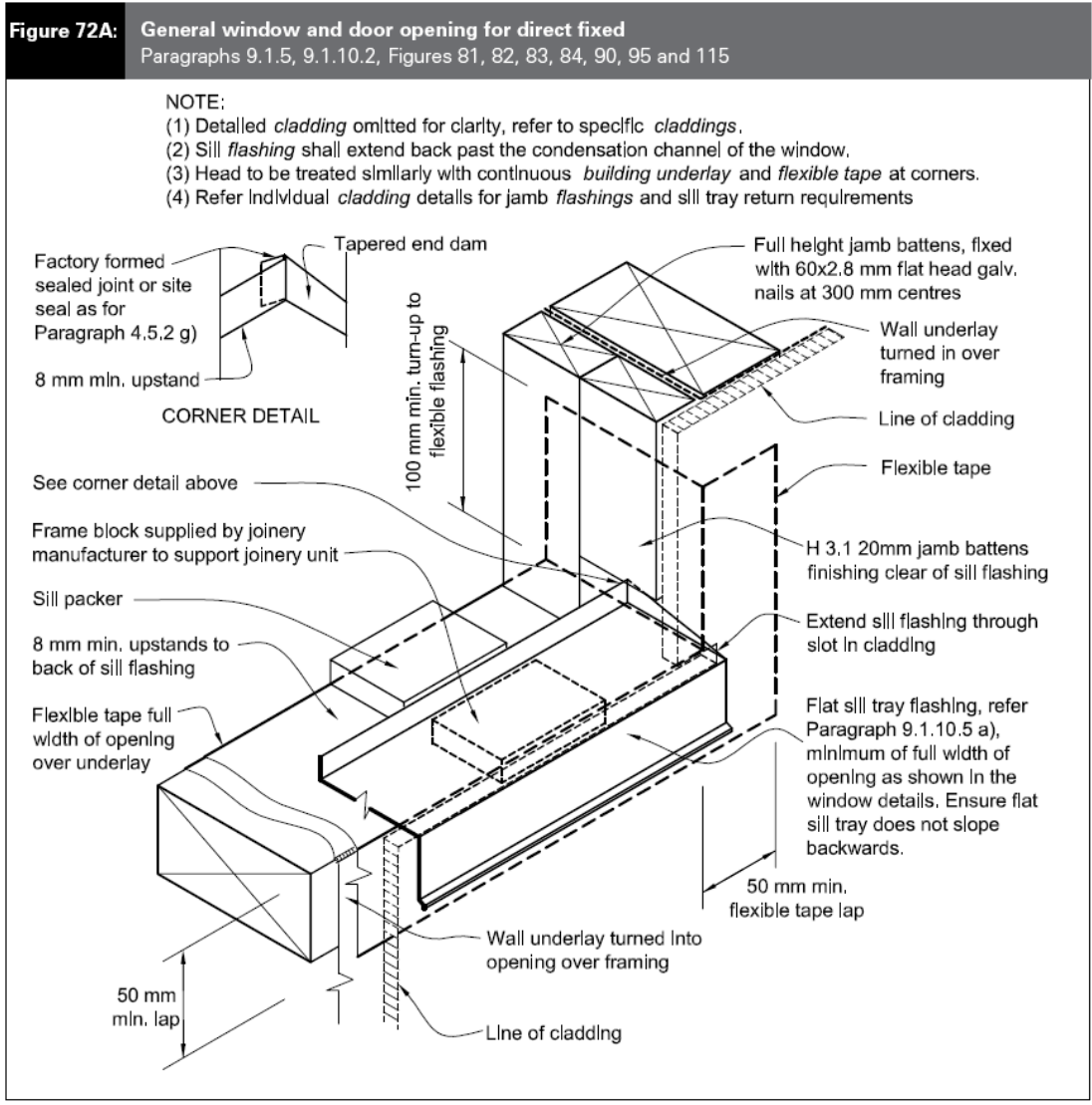

The method of construction is as follows;

- a. Prepare the framed opening, by cutting and fixing the wall flexible underlay and applying the flexible flashing tapes, as described in Steps P1 through P3.

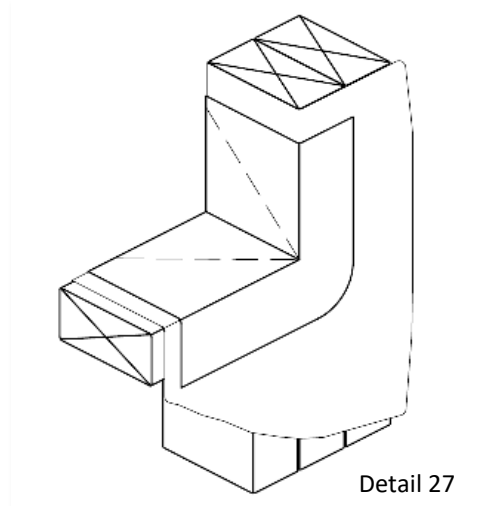

- b. Install the full width sill tray flashing (and stop ends) into the trim opening level, straight and fitted 5mm short of each jamb, packing as required. Ensure that it does not slope toward the interior. At this stage the trim opening is considered between studs and does not include the jamb battens.

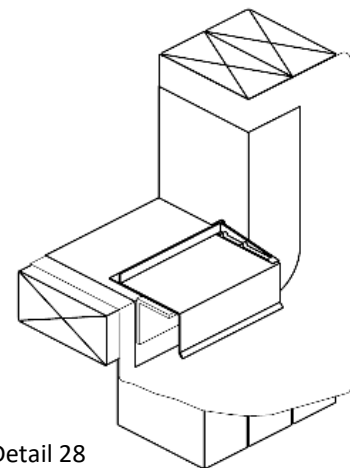

Detail 28



Note: The sill tray flashing is cut 10mm short to allow for the radius / tape build up in the corners of the opening. The tapes must be fitted tight into the corners.

- c. Fix the sill tray flashing into the sill trimmer through the rear leg using either clouts or 8g SS pan head screws positioned 150mm max from each end and at 450mm max centres between. **DO NOT fix forward of the upstand leg!!** With some thicker claddings, the front edge of the sill tray flashing will require additional support. This is achieved through the use of an angle support fitted to the face of the sill trimmer **prior** to the installation of the flashing.

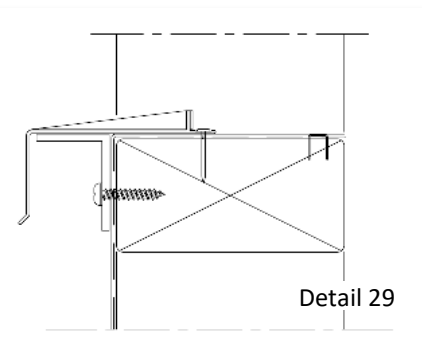

Detail 29



Note: It is important the angle support is installed level regardless of the line of the sill trimmer. It should be fixed with 10g SS screws positioned at each end and at 300mm max centres between.

- d. In order to support the weight of the window or door frame adequately the unit must be blocked up off the sill tray flashing. If your window or door has not been fitted with proprietary frame blocks, then an aftermarket item will need to be sourced and applied in appropriate locations. Refer to your window manufacturer for details.

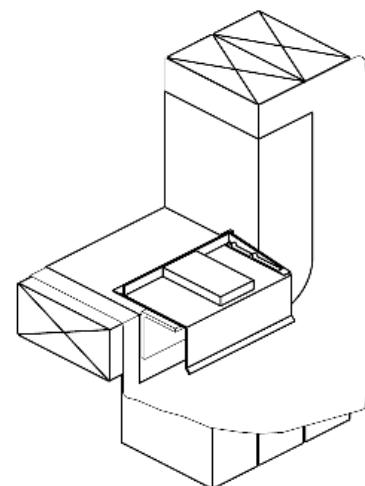

Detail 30

- e. *Figure 72A* (shown on Page 51) describes the addition of full height battens to each jamb of the trim opening. These battens are fitted after all of the trim opening preparation has been completed, including flashing tape, sill tray flashings and end stops.

The battens are used as described in *Clause 9.1.8.4 f)*.

Jamb battens shall:

- f) be nominal 20 mm (between limits of 18 mm and 25 mm in thickness), minimum 45 mm wide, and of timber complying with B2/AS1. Refer to Figure 72A.

Errata 2
Dec 2011

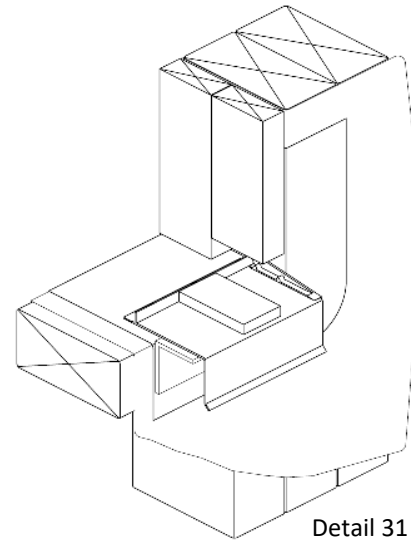

Comment: It would be good practice to bed the inner batten on sealant to help prevent / reduce air leakage around the primary air seal.

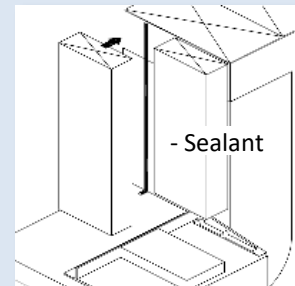

- f. The cladding is now installed and must be notched around the sill tray flashing, and support angle where it is used.

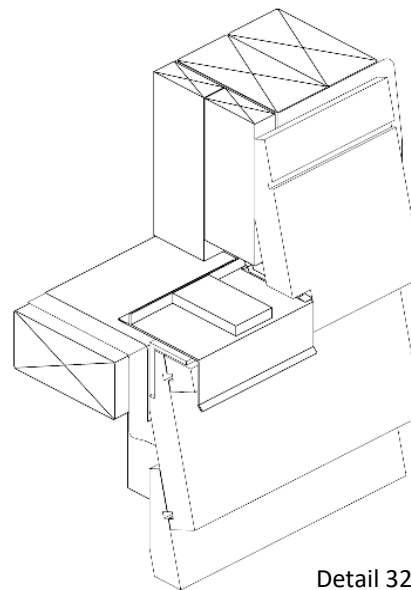

Note: It is important to discuss the building details, including the batten size, with your window manufacturer to ensure the window sizes are calculated correctly.



Step D2 – Position the Unit

- a. Before positioning the window or door unit into the opening ensure, where applicable, that the sill corners have been fitted with corner soaker as described in *Clause 9.1.10.5 c*).

Check with your window manufacturer regarding the types of corner soaker used with their systems and that they are indeed applicable.

c) Mitred aluminium window and door sills, for both *cavity* and *direct fixed*, shall have a corner soaker fitted to the back of the sill/jamb joint and installed at point of manufacture. The soaker will be designed to act as a secondary device to prevent water ingress to the *building* in support of the primary mitre seals. Soaker materials shall be either uPVC, aluminium, polypropylene, high impact styrene or other semi rigid moulded polymeric material.

- b. Ensure the unit is positioned so that;

i) The unit is positioned 5mm forward of the exterior cladding line, as described in *Clause 9.1.10.2 b*),

b) For *direct fixed claddings*, windows and doors shall have a 5 mm stand-off of the flange to the *cladding* to allow for air intrusion to the trim cavity for pressure equalisation. Note that this gap is sealed or trimmed down the jambs, but left open along the sill.

ii) The interior linings will finish in the correct positions,

iii) The unit is sitting correctly on the sill tray flashing,

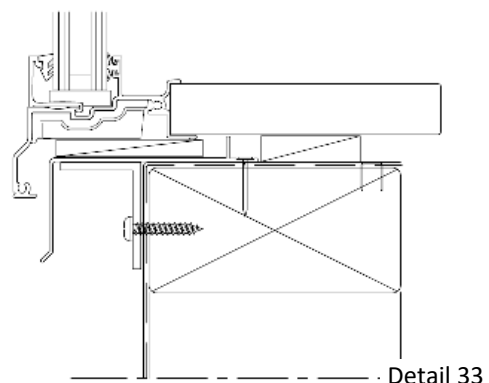

iv) Once the installation has been completed, the required cover over the exterior cladding as described in *Clause 9.1.10*, has been achieved.

After installation, the flange forming the window or door facing shall have an overlap to the surrounding *cladding* material or associated back *flashings* of

- a) For jambs – 10 mm minimum
- b) For sills – 8 mm minimum.

Amend 5
Aug 2011



Step D2a – Position the Unit – Full Height

Figure 17D, describes the sill details for full height window and door units. The positioning of the unit is essentially the same as described in Step D2 above.

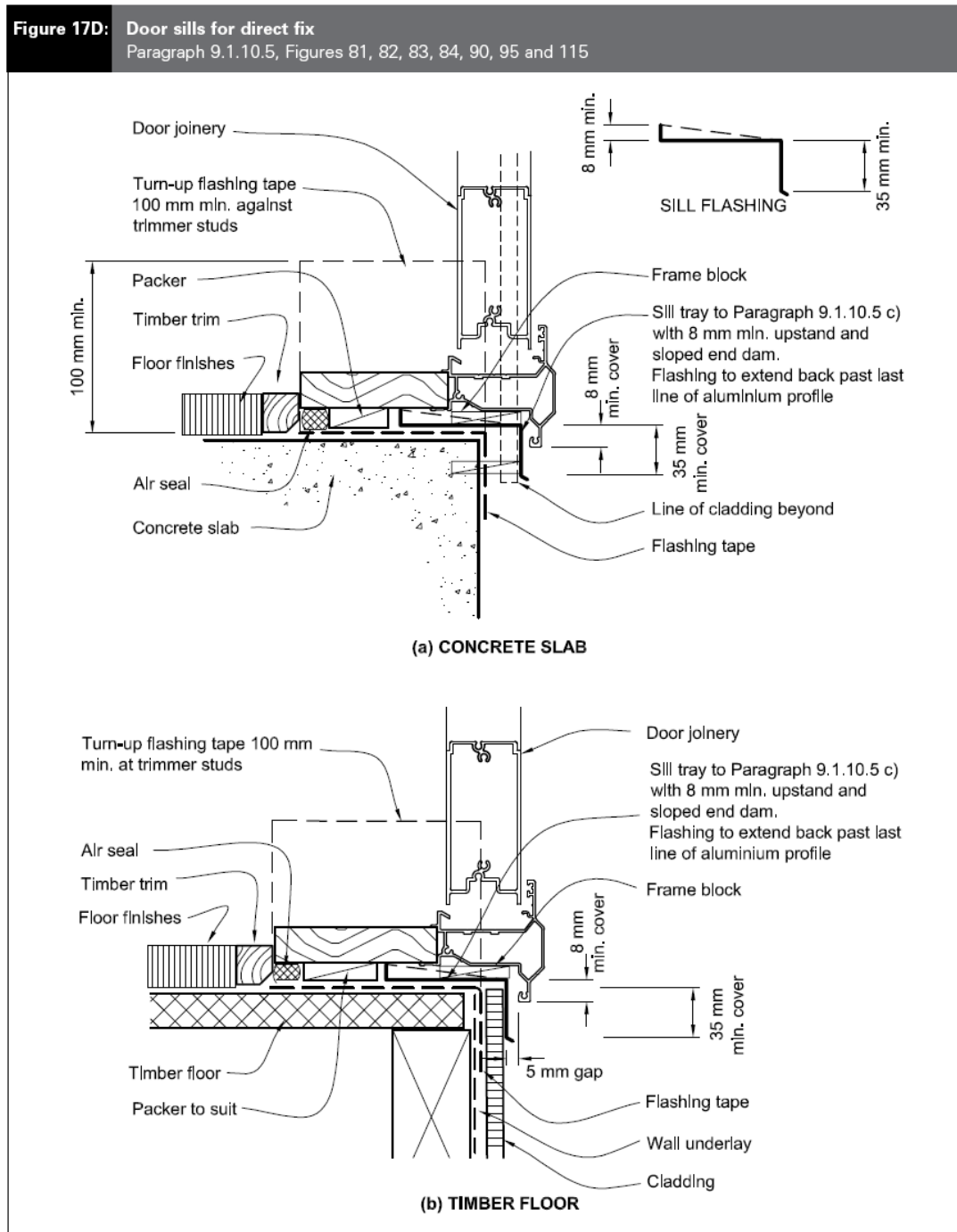



Note: Some find the on-floor details described in Figure 17D to be undesirable. If so then a rebated sill detail will need to be designed for the situation. In this case the rebate becomes the threshold level, i.e. the floor level inside of the window or door is irrelevant to the Acceptable Solution.

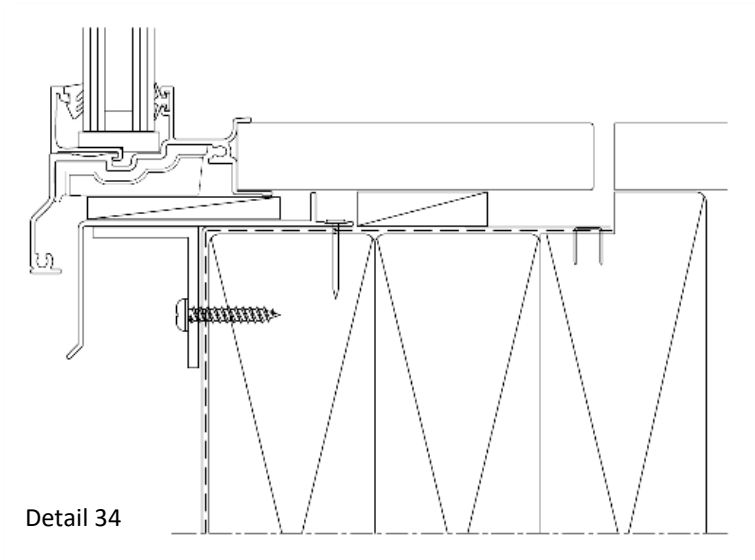

Rebated Timber Floor

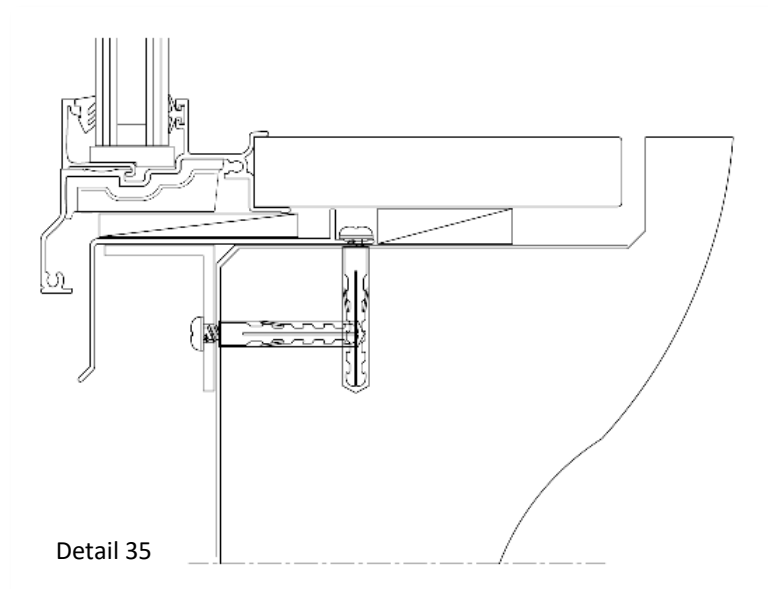

Rebated Concrete Floor



Step D3 – Fixing

- a. Insert flat packers between the wall framing and the window or door reveals at the head, sill and jambs at fixing points. **DO NOT use wedges.**
- b. Fix off the unit as described in *Clause 9.1.10.8.*

9.1.10.8 Attachments for windows and doors

Install windows and doors using pairs of minimum 75 x 3.15 galvanised jolt head nails or 8 gauge x 65 mm stainless steel screws, through reveals into surrounding *framing* at:

- a) Maximum 450 mm centres along sills, jambs and heads, and
- b) Maximum 150 mm from reveal ends.

Install packers between reveals and *framing* at all fixing points, except between head reveals and lintels.

Amend 5
Aug 2011

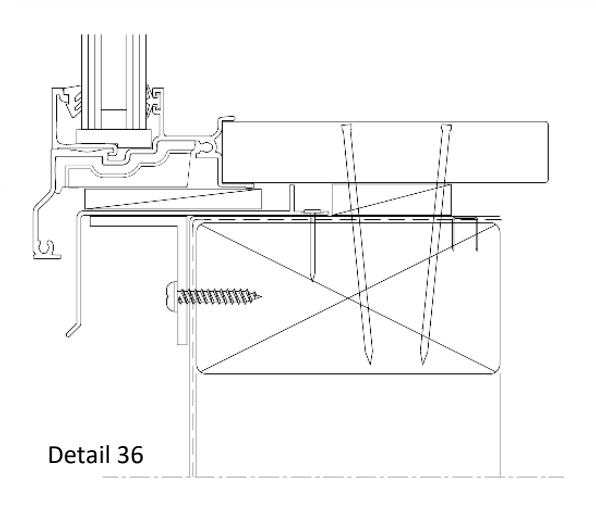

Note 1: This Clause describes the fixing method for typical windows and doors. Larger units or those subject to higher wind loads may require additional fixing. If in doubt, contact your window manufacturer to confirm.

Note 2: Reference is made to pairs of nails or screws. To clarify the reference is pairs of 3.15 nails and pairs of 8g screws.

- c. After fixing the unit in place, remove the packers from the head of the unit to allow any potential settlement of the building structure.

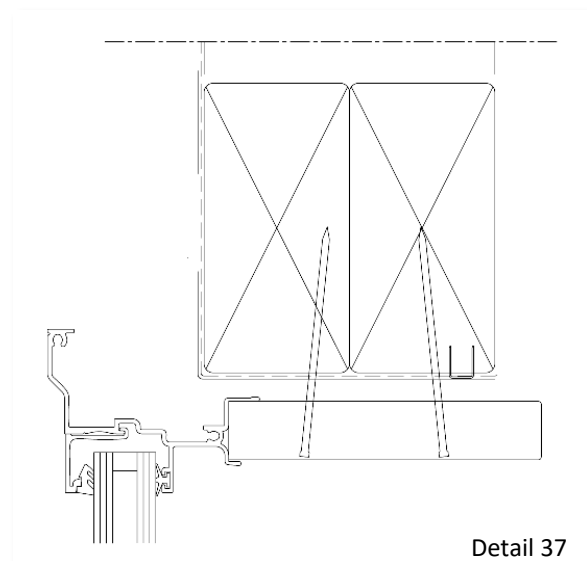



Step D3a – Fixing – Full Height

For full height units fixed to concrete floors replace the nail fixings with 8g x 65mm screws driven into nylon plugs or similar.

If the installer prefers to use masonry anchors, these can be substituted as noted below. Regardless of fixing type, ensure edge clearances, as recommended by the anchor supplier, are observed.

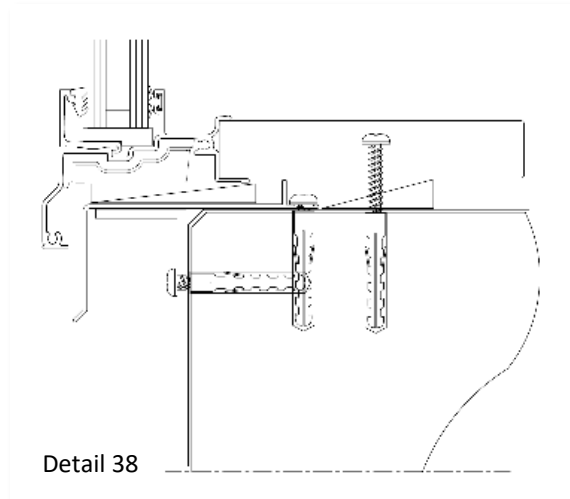

Detail 38



Note: Fixing holes into concrete should be pre-filled with sealant prior to the installation of the fixing as noted in Figure 17A (Page 17).

Fixing Options;

- i. The generic fixing method into timber is pairs of 8g x 65mm SS screws as described in *Clause 9.1.10.8* above.
- ii. When fixing to concrete the same screws and fixing centres apply but the screws would be driven into nylon plugs or similar.
- iii. For concrete the screws may be substituted for 6mm masonry anchors, at the same centres. However, the required edge clearance that these fasteners require must be considered.

For timber floors, ensure the screw fixing is positioned a minimum of 20mm from the edge of the joist. This may require re-drilling of the sill support bar.

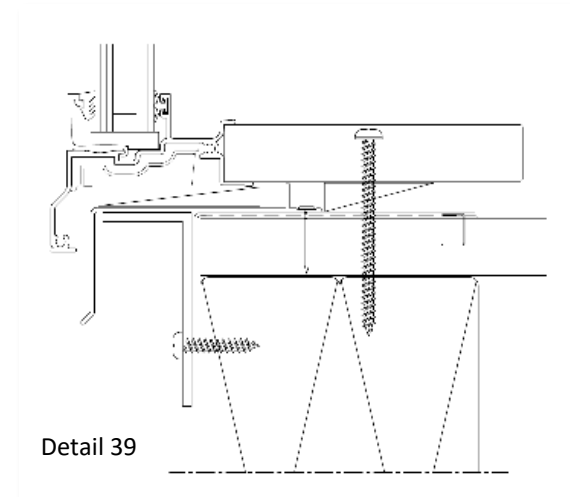

Detail 39



Step D4 – Air Seal

The Air Seal is designed to hold pressure in the trim cavity to enable pressure equalisation to occur. Typically, the Air Seal is a low expansion polyurethane foam installed over a PEF backing rod, as described in *Clause 9.1.6*.

9.1.6 Air seals

Window, door and other penetration openings shall be provided with flexible *air seals* to minimise the risk of airflows carrying water into the *building wall*. The *air seal* shall be:

- a) Provided between the reveal or frame and the wrapped opening (for example of use, refer to Figure 81),
- b) Installed over a closed cell polyethylene foam (PEF) backing rod, or similar
- c) Made of:
 - i) self-expanding polyurethane foam, or
 - ii) sealant complying with:
 - a. Type F, Class 20LM or 25LM of ISO 11600, or
 - b. low modulus Type II Class A of Federal Specification TT-S-00230C.

Amend 5
Aug 2011

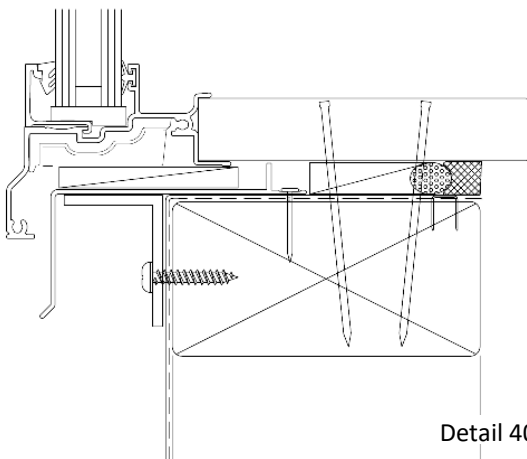

Note: *Clause 9.1.6 makes this comment regarding air seals.*

COMMENT:

Some sealants can react with bitumen based *flashing* tape, preventing full curing of the sealant. Where necessary, consult sealant manufacturers for application requirements.

Backing rods are used for sealant and for self-expanding polyurethane foam as there is a danger foam will expand to the outside of the *wall* and form a moisture bridge to the interior.

For further information refer to ASTM C1330 for backing rod material performance.



Step D5 – Head Flashing

Clause 9.1.10.4 describes the basics of head flashings.

Specifically, paragraphs c) and in some situations e) apply to direct fix construction.

9.1.10.4 Head flashings

Head flashings shall be in accordance with Paragraph 4.6.1.6 and Table 7, unless specifically shown otherwise, and shall:

- a) Direct water to the outside of the wall cladding, and
- b) Finish to the window head with clearance dimensions shown in Figure 71
- c) For direct fixed claddings, have 50 mm bead of sealant installed between cladding and each end of the head flashing
- e) For Very High and Extra High wind zones, have sealant installed between underside of head flashing and top edge of window head flange – refer Figure 71 (c) .

COMMENT:

Stopends are useful to prevent water moving past the ends of head flashings. However, additional problems of weatherproofing occur where the stopend penetrates the cladding.

Detail a) from Figure 81, shows the typical head flashing set out and prescribed dimensions.

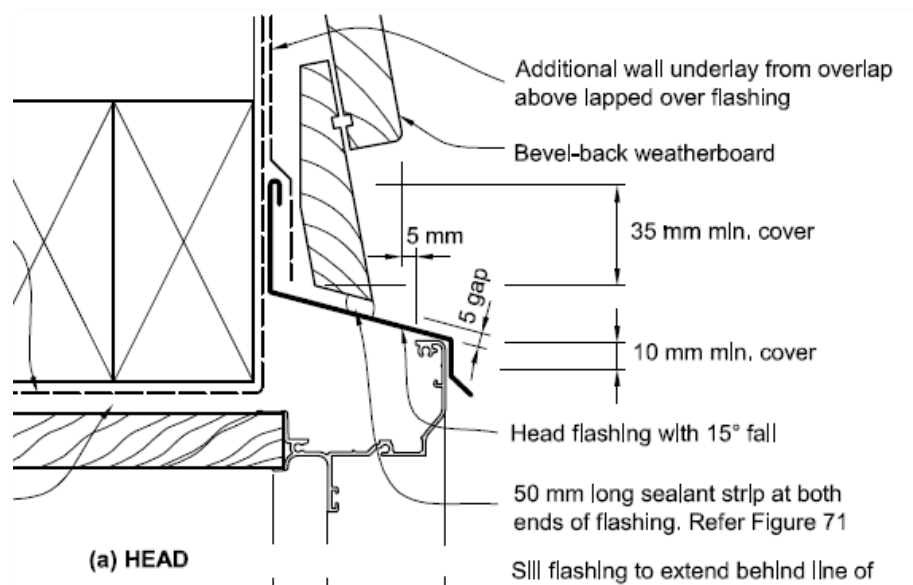

Table 7 describes the upstand cover required by window head flashings.

Table 7: continued		Metal flashings – general dimensions					
		Paragraphs 4.6, 4.6.1.1, 4.6.1.2, 4.6.1.3, 4.6.1.4, 4.6.1.5, 4.6.1.6, 4.6.1.7, 5.1, 6.4, 6.5, 7.4.4, 8.3.8, 9.1.3, 9.1.10.2, 9.1.10.4 and 9.4.5.3					
Membrane roofs and decks	Description	All (1)	Situation 1 (2) minimum mm	Situation 2 (3) minimum mm	Situation 3 (3a) minimum mm	Figure reference (as example)	
	Lap under <i>cladding</i> above	115 min.				Figures 18, 62a, c, 64b	
Heads	Head <i>flashing</i> slope	15° min.				Eg. Figure 81a	
	Lap under <i>cladding</i> above	35 mm min.			60 mm	Eg. Figure 81a	
	Anti-capillary gap to <i>cladding</i>	5 mm				Eg. Figure 81a	
	Total upstand	40 mm min.					

The most common form of window or door head flashing is the extruded aluminium version, chosen primarily because of its consistent dimension and ease of installation. Those supplied by WANZ members are available to suit a wide range of claddings. These extruded flashings are designed to provide a nominal 5mm gap between the back of the flashing and the face of the window.

4.5.1 Edge treatments for flashings

Flashings shall be to the dimensions shown throughout this Acceptable Solution.

Exposed bottom edges of *flashings* shall be folded to a *kick-out* or a *bird's beak* as shown in Figure 5.

For Low, Medium, High and Very High *wind zones*, *flashing upstands* shall have either:

- 1) A *hem* or *hook* to Figure 5, with upstand dimensions as shown throughout the document, or
- 2) No *hooks* or *hems*, and *flashing upstand* dimensions increased by 25 mm beyond those shown.

For Extra High *wind zones*, *hooks* and *hems* shall be used, and *flashing upstand* dimensions increased by 25 mm beyond those shown in Table 7 or elsewhere in the document.



Note: E2/AS1 Amendment 10 does not prescribe the offset of the head flashing from the face of the window flange. As noted above WANZ members offer head flashings designed to provide a nominal 5mm gap between the flashing and the window is achieved, similar to that shown below the cladding. The gap helps to avoid capillary action drawing water over the head of the window.

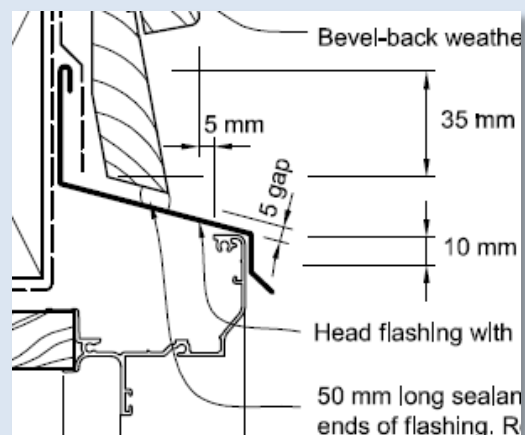

It is industry standard to extend the length of the head flashing 20mm past each side of the window, i.e. window width +40mm.

In cases where jamb scribers are used, these are considered as a part of the window width and therefore the +40mm is added to the overall scriber dimension.

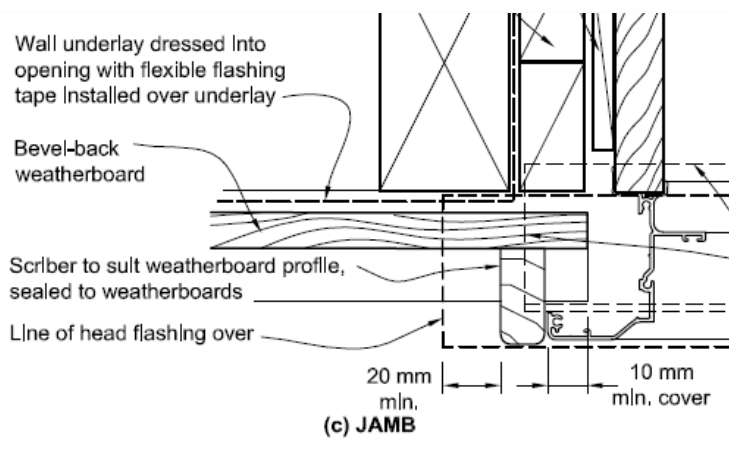

This is described in each of the window details shown within E2/AS1 Amendment 10.

Clause 9.1.10.4 c) states;

c) For *direct fixed claddings*, have 50 mm bead of sealant installed between *cladding* and each end of the *head flashing*

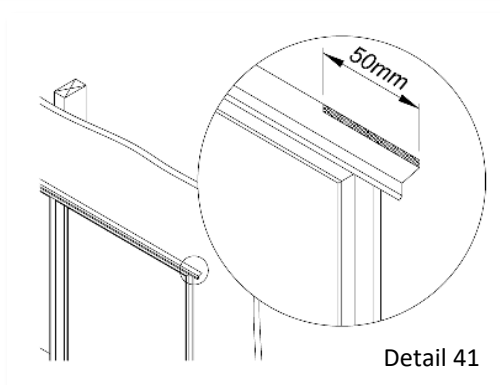
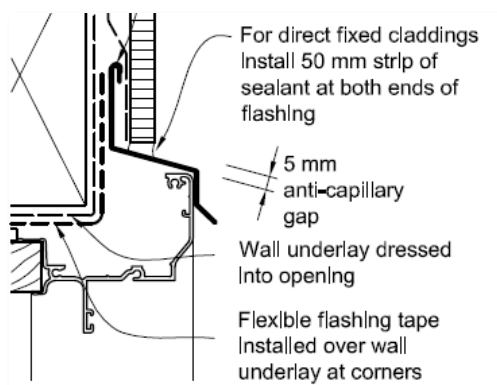
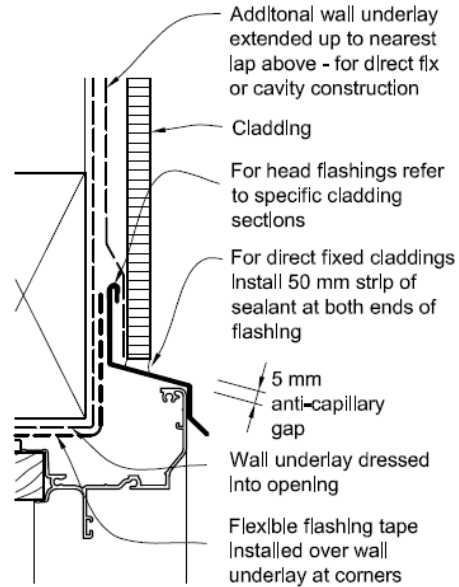

Figure 71, describes the general set out of the head flashing and the wall underlay options. Whilst these details are shown as direct fix situations the same will apply to cavity construction.

Figure 71: General sealing of head flashing
Paragraphs 9.1.7, 9.1.10.3 and 9.1.10.4

NOTE: May also use *wall underlay* lapped over flashing upstand in lieu of *flexible flashing tape*. Refer cladding window details, for example Figure 115.



(a) METAL HEAD FLASHING - WITH ADDITIONAL UNDERLAY OPTION

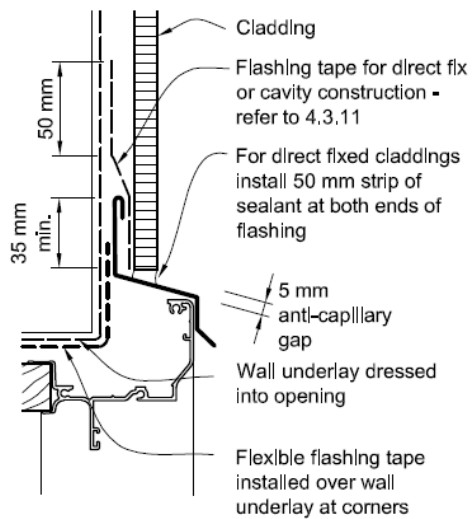

(b) METAL HEAD FLASHING WITH FLASHING TAPE OPTION

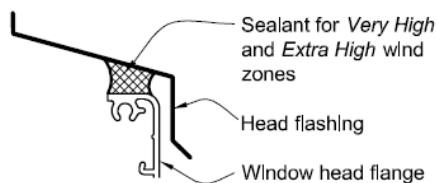

(c) METAL HEAD FLASHING SEALANT FOR VERY HIGH AND EXTRA HIGH WIND ZONES

Amend 5
Aug 2011



Note: Detail (c) shows sealant between the top of the window or door flange and the underside of the head flashing. Use of a closed cell foam tape in this case might simplify the application. The detail applies to Very High wind zones only.



Note: Windows or doors that extend to the soffit do not require a head flashing but instead will have a trim fitted as shown in Figure 8A f).

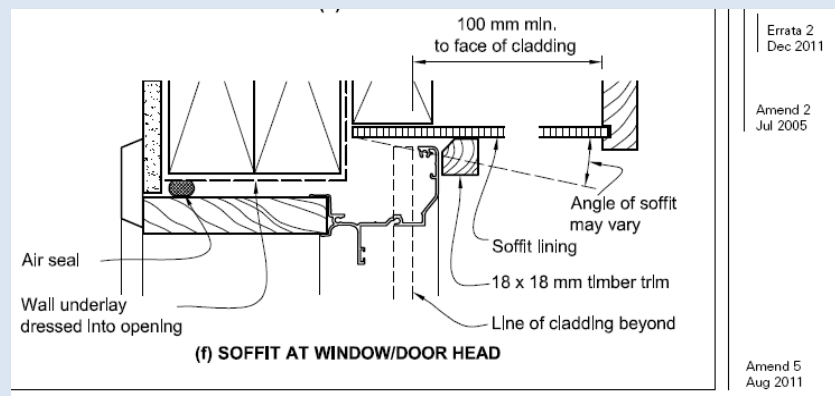

Refer to pages 31-36 for details relating to installation up to a soffit.



WANZ Components – Direct Fix Claddings

Components

Head Flashing

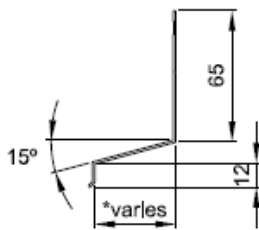

Material: Extruded Aluminium
 *Note: Dimension varies with cladding type
 Available in 5mm Increments

Sill Pans

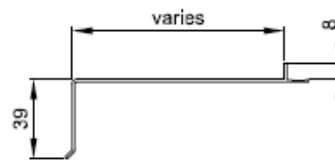

Material: Extruded Aluminium

Support Angles

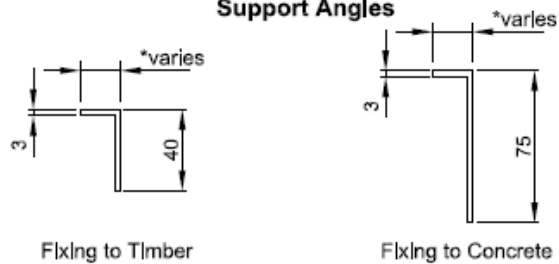

Material: Extruded Aluminium
 *Note: Dimension varies with cladding type

WANZ Sill Pan Stop End

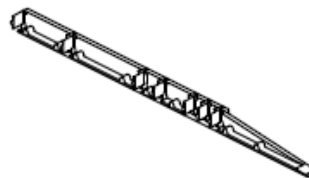

*Note: These parts form part of the window system and should be supplied by your window manufacturer.

Material: Moulded Polypropylene

Direct Fix Claddings Typical Details

Figure 81: Windows and doors for direct fixed bevel-back weatherboards
Paragraph 9.4.6

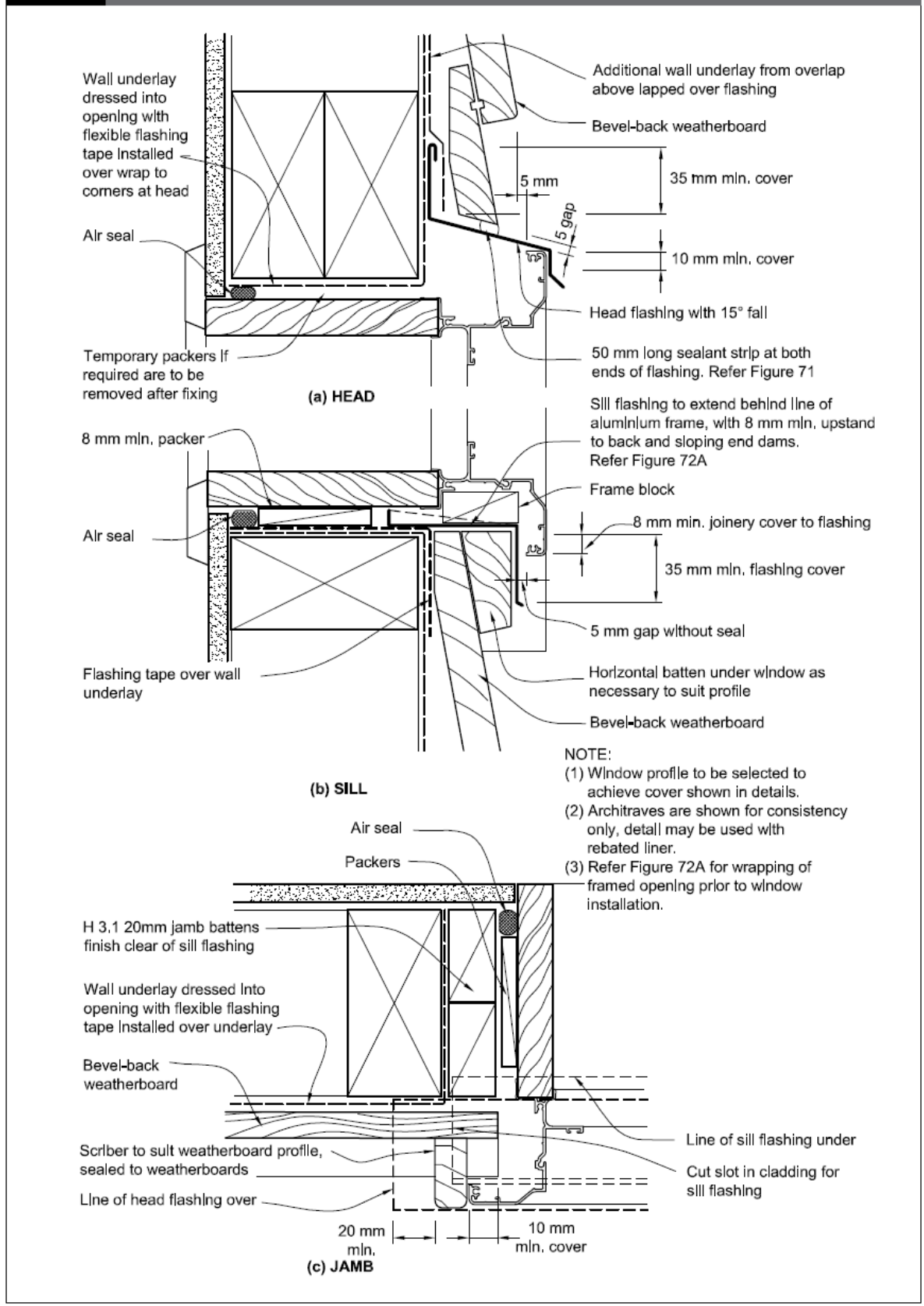

Figure 82: Windows and doors for direct fixed rusticated weatherboards
Paragraph 9.4.6

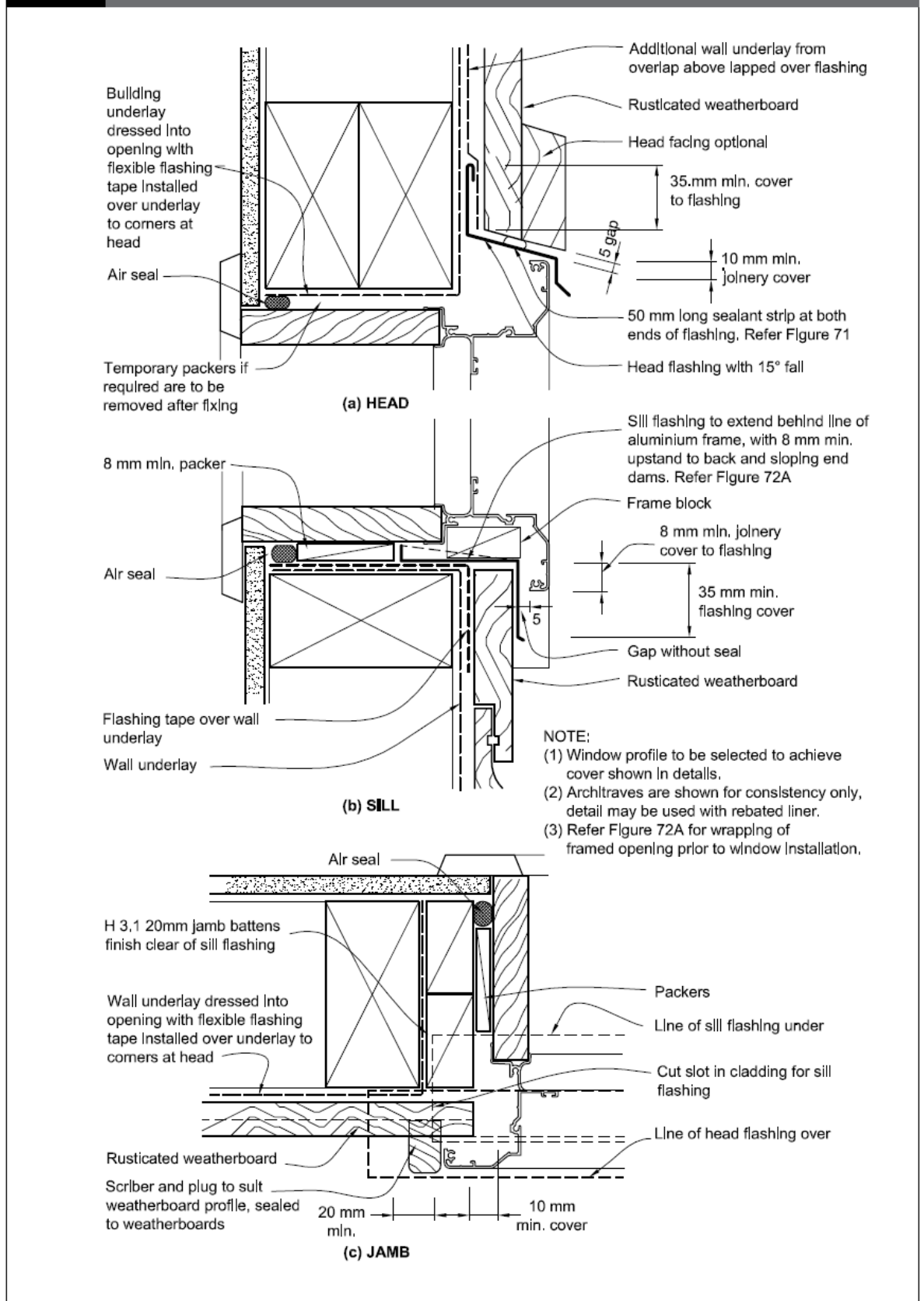
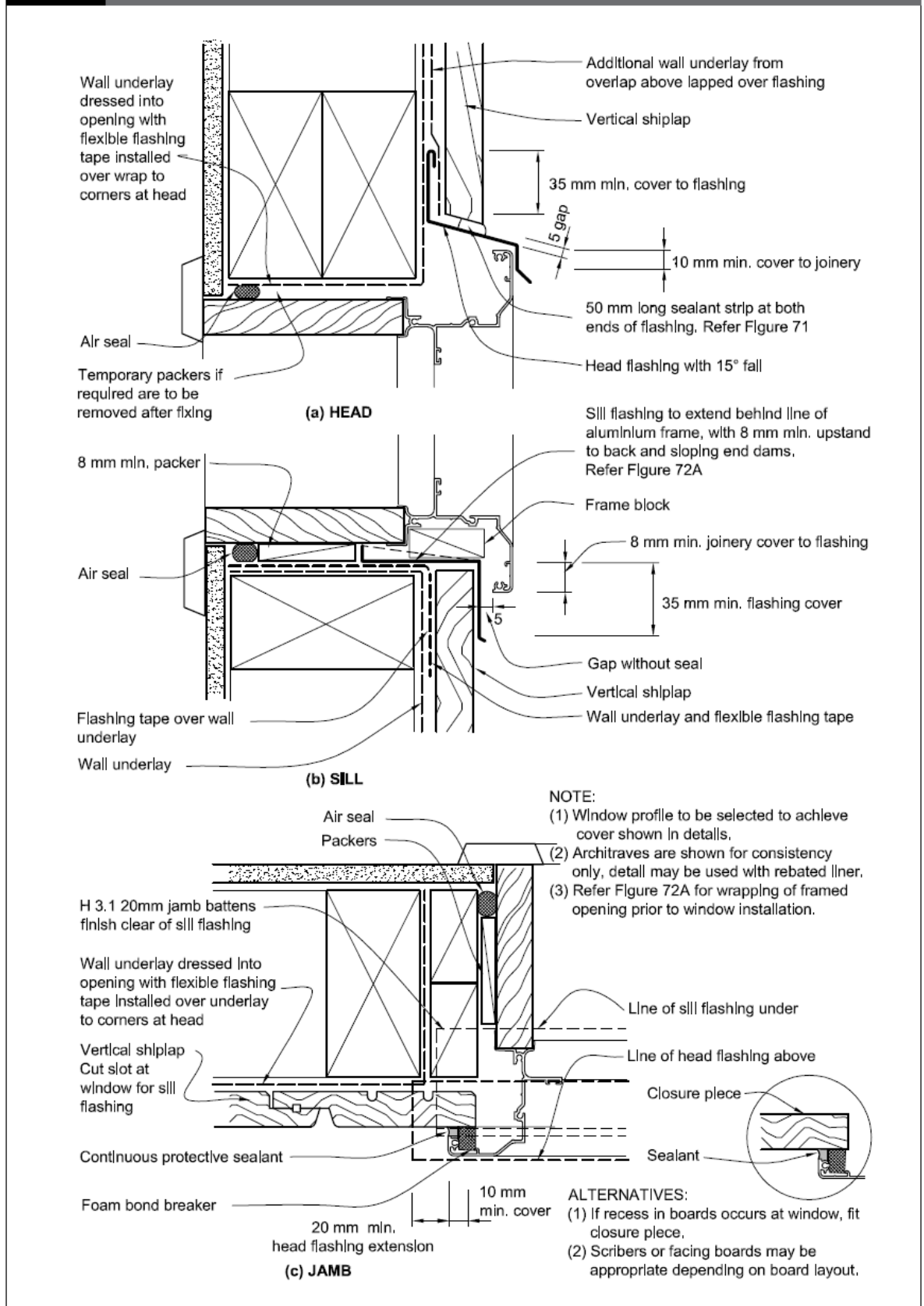

Figure 83: Windows and doors for direct fixed vertical shiplap weatherboards
Paragraph 9.4.6



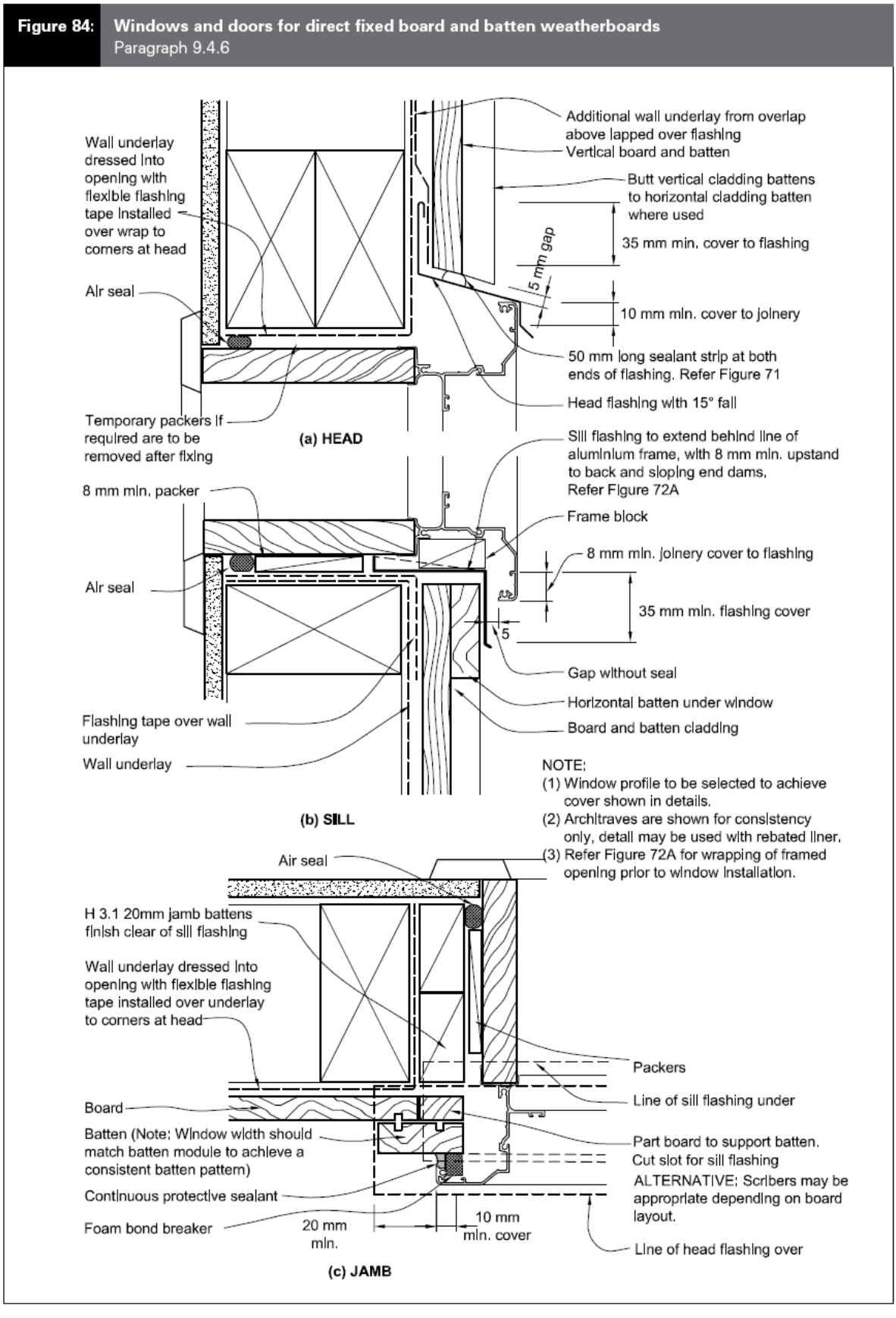
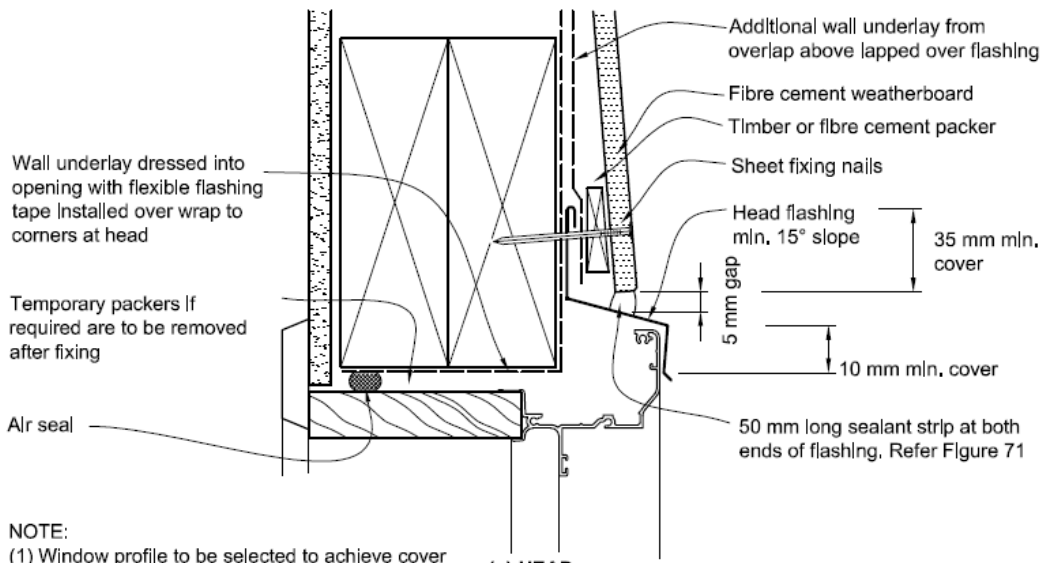
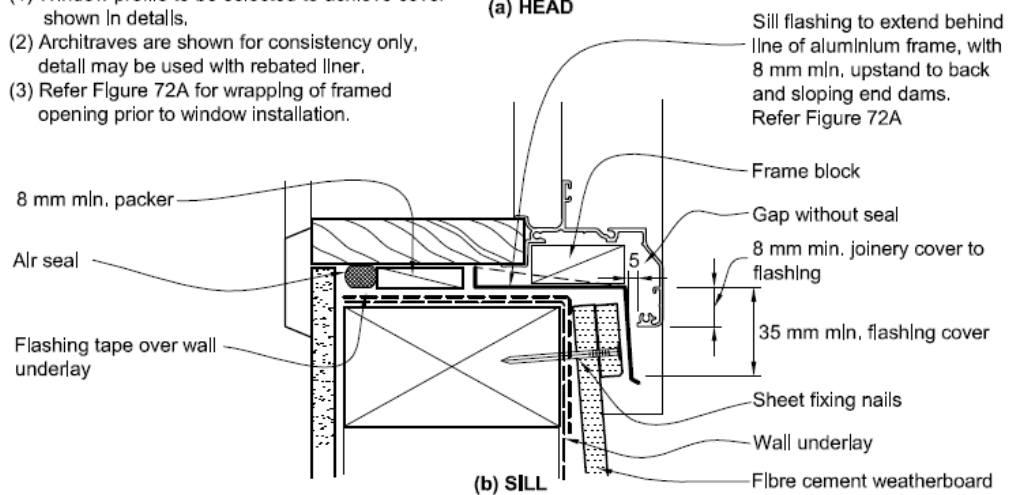

Figure 90: Windows and doors in fibre cement direct fixed weatherboards
Paragraph 9.5.4.1



NOTE:
 (1) Window profile to be selected to achieve cover shown in details.
 (2) Architraves are shown for consistency only, detail may be used with rebated liner.
 (3) Refer Figure 72A for wrapping of framed opening prior to window installation.

(a) HEAD



(b) SILL

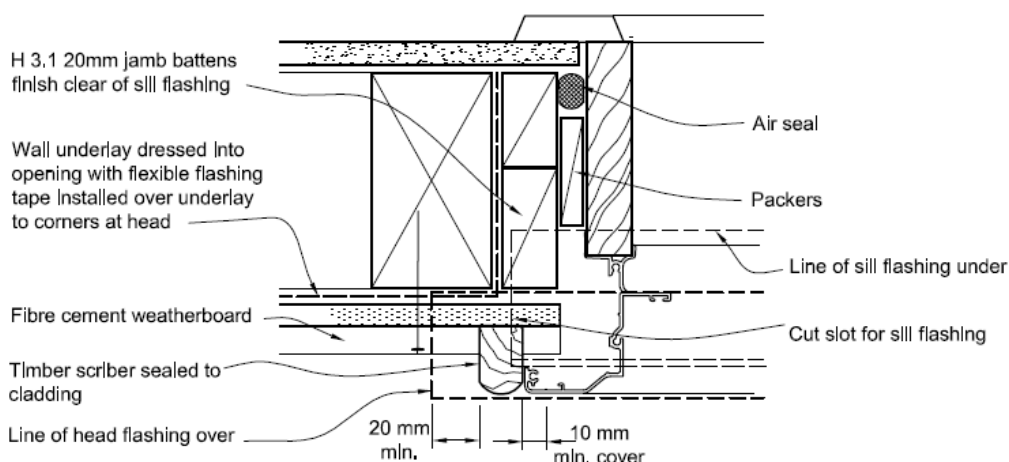

(c) JAMB

Figure 95: Windows and doors for vertical profiled metal
Paragraph 9.6.8.6

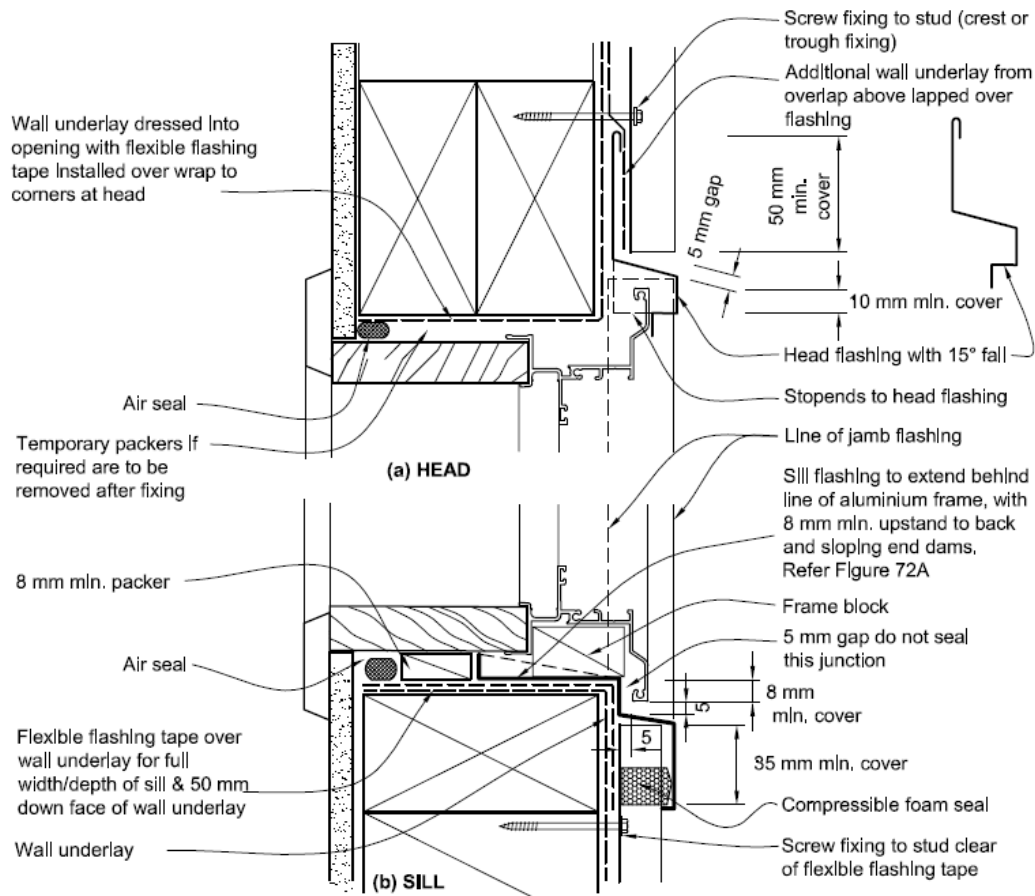

NOTE:

- (1) Window profile to be selected to achieve cover shown in details.
- (2) Architraves are shown for consistency only, detail may be used with rebated liner.
- (3) Refer Figure 72A for wrapping of framed opening prior to window installation.
- (4) Refer Figure 100 for sketch of flashings.
- (5) Refer Figure 71 (c) for sealant at head for *Very High* and *Extra High* wind zones.

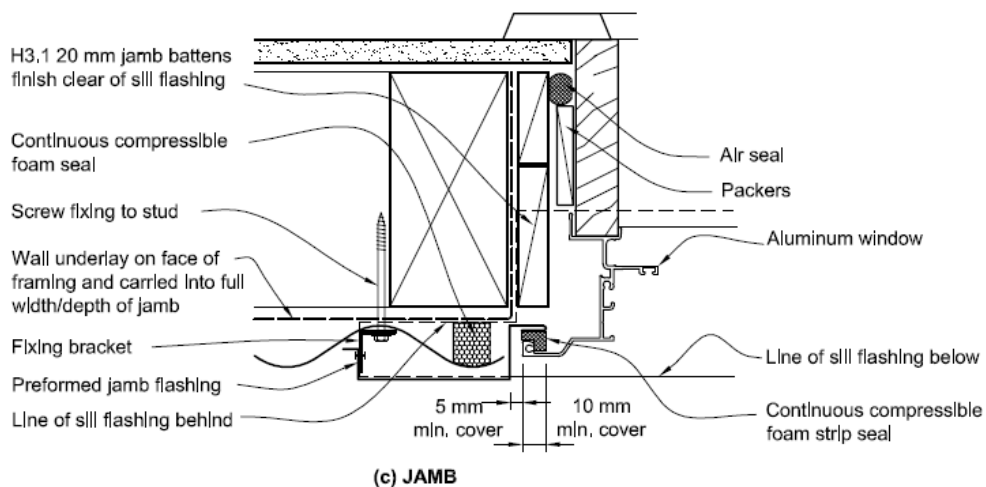
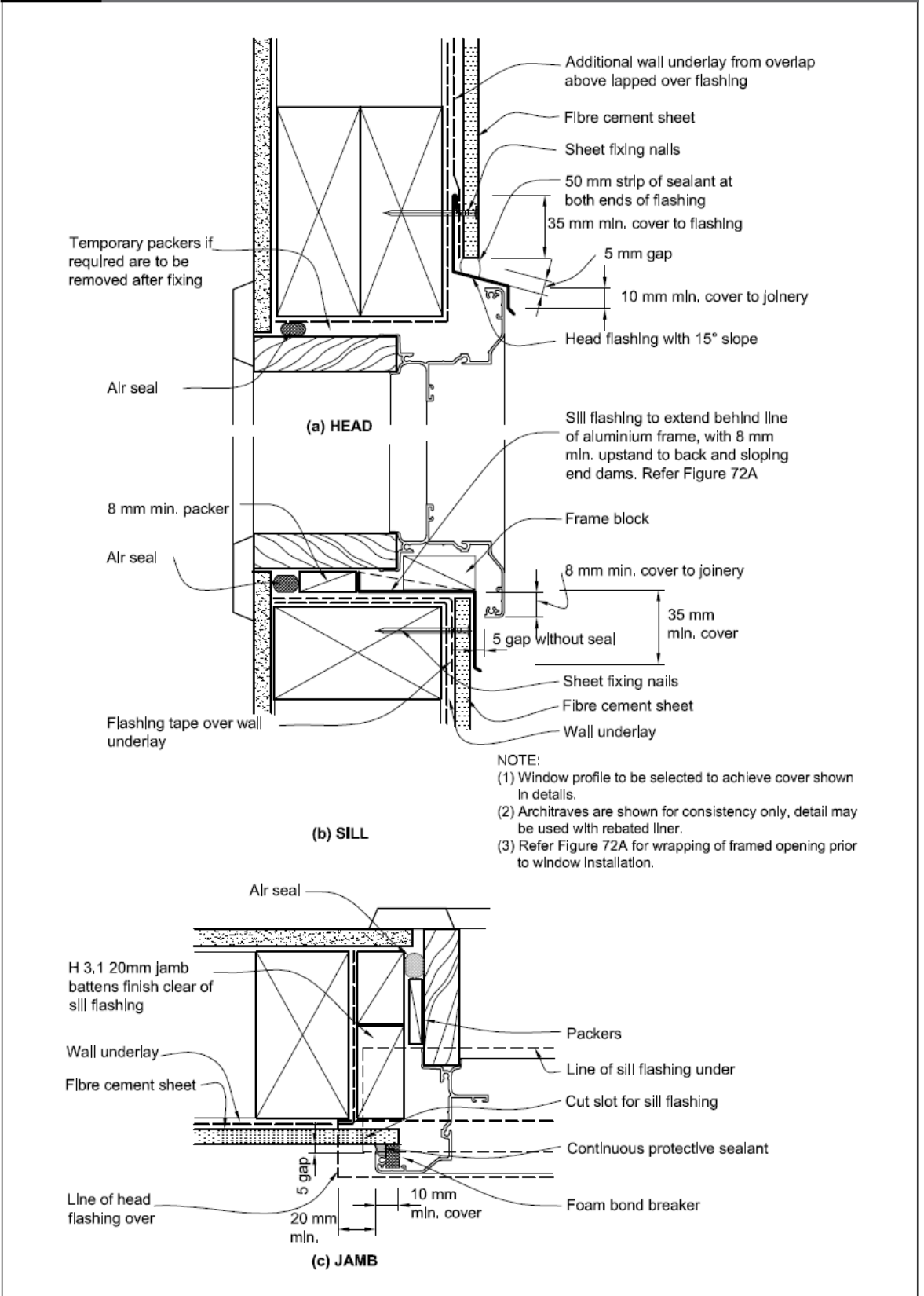

Figure 115: Windows and doors for direct fixed fibre cement sheet
Paragraph 9.7.6



Any questions?

At UNO Windows & Doors, we're here to help.

For more advice and effective solutions, chat to one of our friendly team.

enquiries@unowindows.co.nz

06 272 9080

unowindows.co.nz

